

DATA SHEET

SAA7391 ATAPI CD-R block encoder/decoder

Objective specification
File under Integrated Circuits, IC01

1997 Aug 01

ATAPI CD-R block encoder/decoder**SAA7391**

CONTENTS			
1	FEATURES	7.5.11	DMA transfers in generic mode
2	GENERAL DESCRIPTION	7.5.12	Normal DMA mode
2.1	Memory mapped control registers	7.5.13	Burst DMA mode using multiplexed bus configuration
2.2	Error correction features	7.6	Microcontroller interface
2.3	Host interface features	7.6.1	Kernel based firmware
2.4	Buffer memory organisation	7.6.2	16-bit registers automatic read and write
2.5	Subcode handling features	7.7	8051 CPU and memory management functions
2.6	Multimedia output audio control features	7.7.1	Sub-CPU bus access timing
3	QUICK REFERENCE DATA	7.7.2	Buffer memory organisation
4	ORDERING INFORMATION	7.7.3	Subpage
5	BLOCK DIAGRAM	7.8	External memory interface
6	PINNING	7.8.1	DRAM interface configuration register
6.1	Detailed description of pin functions	7.9	UART for communication with CD engine
7	FUNCTIONAL DESCRIPTION	7.9.1	UART basic engine interface
7.1	Memory field description	7.10	Clock generation control
7.1.1	DVD-ROM memory field information	7.10.1	Crystal oscillator
7.2	CD input control registers	7.10.2	Sub-CPU clock control register
7.2.1	Registers associated with data in process	7.10.3	SAA7391 system clock control registers
7.3	Multimedia output interface	8	LIMITING VALUES
7.3.1	Subcode input block	9	THERMAL CHARACTERISTICS
7.3.2	Subcode mode transmit control register	10	CHARACTERISTICS
7.3.3	General description of the multimedia output interface	11	TIMING CHARACTERISTICS
7.3.4	IEC 958/EBU output	11.1	External memory interface timing
7.3.5	Memory-to-memory block copy function	11.2	Host interface timing
7.4	Interrupt registers	11.2.1	Host interface ATAPI PIO and DMA timing
7.4.1	Interrupt 1	11.2.2	ATA bus timing
7.4.2	Interrupt 2	11.2.3	Ultra DMA operation and timing
7.4.3	UART interrupt	11.2.4	Ultra DMA read/write timing
7.5	Host interface	11.3	Sub-CPU interface timing
7.5.1	Introduction	11.4	UART timing
7.5.2	Description of the host interface block	12	APPENDIX A
7.5.3	Description of the host interface registers	13	APPLICATION INFORMATION
7.5.4	Transfer counter	14	PACKAGE OUTLINE
7.5.5	Packet size store	15	SOLDERING
7.5.6	Sequencer status	15.1	Introduction
7.5.7	Host interface DMA special bits	15.2	Reflow soldering
7.5.8	Automatic block pointer reload programming	15.3	Wave soldering
7.5.9	DMA transfer programming of the host interface	15.4	Repairing soldered joints
7.5.10	Generic interface operation	16	DEFINITIONS
		17	LIFE SUPPORT APPLICATIONS

ATAPI CD-R block encoder/decoder

SAA7391

1 FEATURES

- Supports real time error detection and correction in hardware. Error correction to $n = 27$, error detect to $n = 30$ and raw data transfer to $n = 32$.
- CD-R to CD-n greater than 8. Internal operation is faster, but firmware and physical (laser/media) factors limit the speed
- DVD-ROM supported in combination with the SAA7335
- Direct generic interface to external Small Computer Systems Interface (SCSI) controller devices
- Operates with up to 16 Mbytes DRAM
 - Hyper-page DRAM up to 33 Mbytes words/s burst
 - Fast-page DRAM at up to 17.5 Mbytes words/s burst
- Has fixed $n = 1$ or $n = 2$ rate (44.1 or 88.2 kHz) I²S-bus multimedia output for simple audio/video output; features for CAV/quasi-CLV support
 - Supports Philips multimedia audio CODEC
 - Provides 'SHOARMA' Red Book audio buffer
- IEC 958 (SPDIF, AES/EBU and DOBM) output with Q-W subcode and programmable category code, output at $n = 1$ rate
- Device registers are memory mapped for faster direct access to the chip
- Provides direct access from sub-CPU to buffer RAM to support scratchpad accesses. This eliminates the need for extra RAM chips in the system
- Automatic sequencing of ATAPI packet command protocol, including command termination
- Automated data transfers to and from the host using PIO, DMA and ultra DMA.

2 GENERAL DESCRIPTION

The SAA7391 is a block decoder/encoder and buffer manager for high-speed CD-ROM/CD-R functions, that integrates real time error correction and detection and bidirectional ATAPI transfer functions into a single chip.

2.1 Memory mapped control registers

The SAA7391 device has a large number of memory mapped registers. These are arranged so that high-level languages see the registers as external byte or 16-bit integer quantities. The block addressing of the SAA7391 facilitates the use of pairs of 16-bit quantities to represent addresses.

The reading and writing of 16-bit registers within the device can be performed by two separate 8-bit reads, where the second byte data is latched at the same time as the first byte is read.

2.2 Error correction features

The SAA7391 has an on-chip 36 kbits memory that is used as a buffer memory for error and erasure correction processing. This buffer memory reduces the number of external RAM accesses that are needed for error correction and thus allows for an increased rate of data throughput.

The error corrector is switchable between two-pass, single-pass [both with Error Detection/Correction (EDC)] and EDC only modes to further improve throughput. The presence of the full error corrector removes the need for firmware based control of the error corrector's operation.

2.3 Host interface features

The SAA7391 has an ATAPI host interface that may be directly connected to the ATAPI bus thereby reducing the need for external support devices. It supports PIO Mode 4 transfer and Mode 0 ultra DMA. This interface can also be configured as a generic DMA interface for use with external host interface devices (e.g. SCSI controller). The DMA interface has the following features:

- ATAPI command packets are automatically loaded into the command FIFO
- Data transfer to the host is automatically sequenced to reduce inter-block latencies and improve host CPU utilisation
- Host data transfer rate is independent of error corrector operation and the data input path
- The host interface features automatic determination of block length for Mode 2, Form 1 and Form 2 sectors. The block length transferred is programmable.
- The host interface can transfer up to 3 sub-blocks per sector, with each sub-block being transferred dependent on the Form bit. Automatic reload of sub-block pointers and unconditional transfer are supported.

ATAPI CD-R block encoder/decoder

SAA7391

2.4 Buffer memory organisation

Memory is mapped as a 16-bit block number and 12-bit offset into that block. The block oriented memory structure permits the use of 16-bit pointers in software thereby minimising the overhead of accessing memory.

The address can be found from the following equation:
address = block number \times 2560 + offset.

The microcontroller sees the SAA7391 as a memory mapped peripheral, with control and status registers appearing in the upper address space.

The lowest 52 kbytes (48 kbytes + 4 kbytes) of the 8051 microcontroller external address space is mapped as a window into the memory on a user-specified 1 kbyte boundary within the buffer RAM. This can be used as a scratchpad memory.

The next 4 kbytes is separately mapped as a window into the memory on a user-specified 1 kbyte boundary within the RAM.

The next 7.5 kbytes of the external data space consists of three independently addressed memory segments for accessing block data, subcode information and block headers.

The registers of the SAA7391 are mapped into the top 256 bytes of external data space.

2.5 Subcode handling features

The writing of data into the buffer RAM is aligned to the absolute time sync marker with the following features:

- Subcodes are written into memory together with their associated sector data. This eases the provision of specialist features, for example CD + G or Karaoke CD applications.
- All channels of subcode are de-interleaved
- The Q channel is also Cyclic Redundancy Checked (CRC) for increased reliability
- When operating in 3-wire subcode mode, it is possible to control or read the P bit in the P-W subcode stream.

2.6 Multimedia output audio control features

The I²S-bus input may be processed before feeding to the multimedia audio output in several simple ways:

- As audio is transferred via the buffer memory, it is not necessary to have the CD-DSP I²S-bus input at exactly the audio $n = 1$ or video $n = 2$ rate. Any faster speed will work because the buffer RAM is used as a FIFO.
- Both channels may be independently controlled. The left channel output may be sourced from zero (digital silence), left or right input; this also applies for the right channel output. This permits basic audio switching and channel swapping.
- IEC 958 (SPDIF, AES/EBU and DOBM) output with Q-W subcode and programmable category code, can be output from the same CD-DSP I²S-bus data source.

3 QUICK REFERENCE DATA

SYMBOL	PARAMETER	MIN.	TYP.	MAX.	UNIT
V _{DDD(core)}	digital core supply voltage	3.0	3.3	3.6	V
V _{DDD(pad)}	digital peripheral supply voltage	V _{DDD(core)}	5.0 or 3.3	5.0	V
I _{DDD}	supply current	tbf	60	tbf	mA
f _{xtal}	crystal frequency	8	8.4672, 16.9344 or 33.8688	35	MHz
T _{amb}	operating ambient temperature	0	–	70	°C
T _{stg}	storage temperature	–55	–	+125	°C

4 ORDERING INFORMATION

TYPE NUMBER	PACKAGE		
	NAME	DESCRIPTION	VERSION
SAA7391H	LQFP144	plastic low profile quad flat package; 144 leads; body 20 \times 20 \times 1.4 mm	SOT486-1

ATAPI CD-R block encoder/decoder

SAA7391

5 BLOCK DIAGRAM

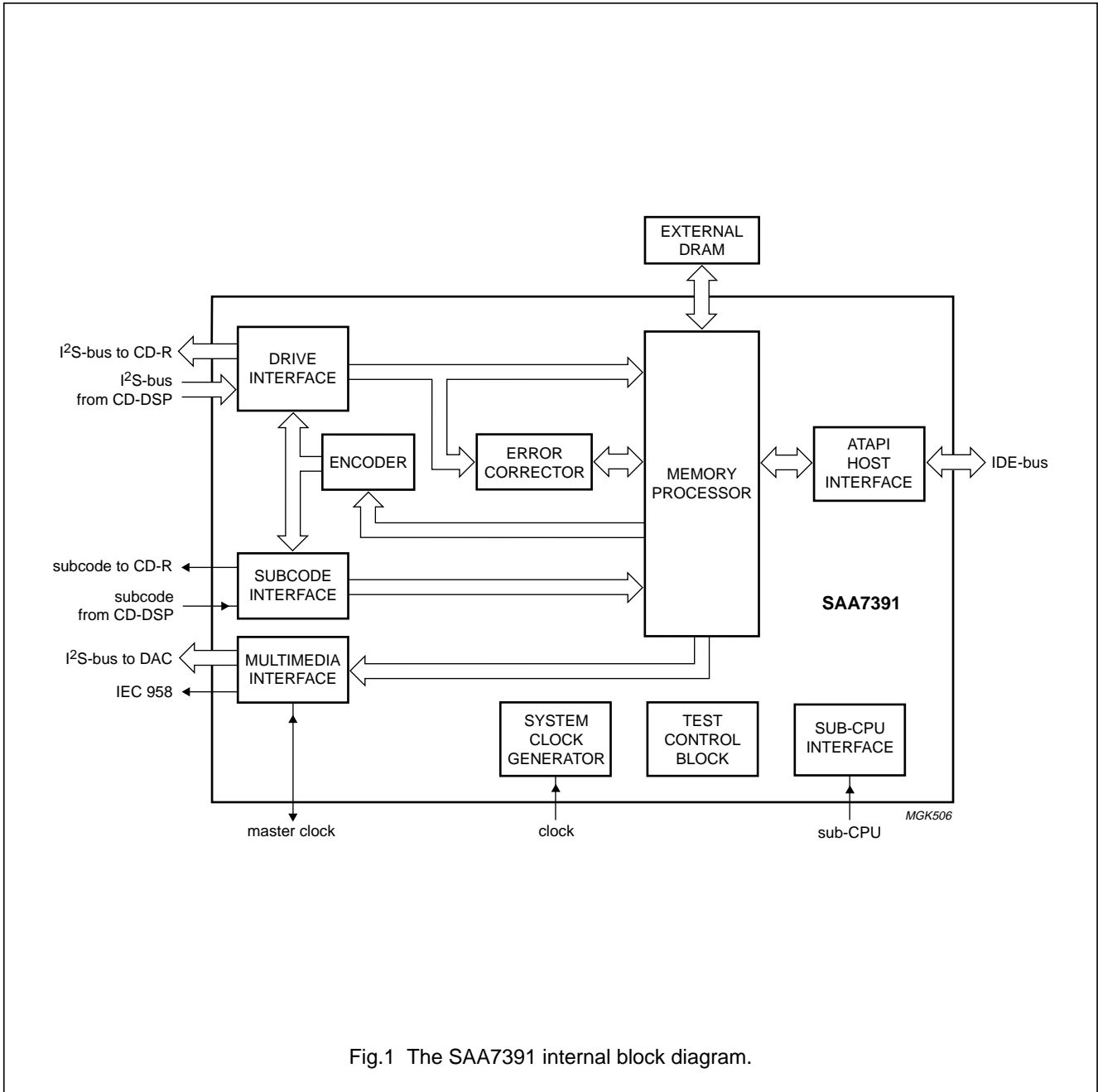

Fig.1 The SAA7391 internal block diagram.

ATAPI CD-R block encoder/decoder

SAA7391

6 PINNING

SYMBOL	PIN	TYPE	DRIVE/ THRESHOLD	GROUPING	DESCRIPTION
n.c.	1	–	–	–	not connected
n.c.	2	–	–	–	not connected
XDA0	3	O	M	RAM	output address lines
XDA1	4	O	M		
XDA2	5	O	M		
V _{DDD(pad6)}	6	–	–	–	digital peripheral supply voltage 6
DGND1	7	–	–	–	digital ground 1
XDA3	8	O	M	RAM	output address lines
XDA4	9	O	M		
XDA5	10	O	M		
XDA6	11	O	M		
XDA7	12	O	M		
XDA8	13	O	M		
XDA9	14	O	M		
XDA10	15	O	M		
XDA11	16	O	M		
DGND2	17	–	–	–	digital ground 2
$\overline{\text{X}}\text{RAS}$	18	O	H	RAM	row address strobe output (active LOW)
$\overline{\text{X}}\text{CAS}$	19	O	H		column address strobe output (active LOW)
$\overline{\text{X}}\text{WR}$	20	O	H		write enable output (active LOW)
XDD0	21	I/O	M/T	RAM	data bus input/output
XDD1	22	I/O	M/T		
V _{DDD(core1)}	23	–	–	–	digital core supply voltage 1
DGND3	24	–	–	–	digital ground 3
XDD2	25	I/O	M/T	RAM	data bus input/output
XDD3	26	I/O	M/T		
XDD4	27	I/O	M/T		
XDD5	28	I/O	M/T		
XDD6	29	I/O	M/T		
XDD7	30	I/O	M/T		
V _{DDD(pad7)}	31	–	–	–	digital peripheral supply voltage 7
DGND4	32	–	–	–	digital ground 4
SCKI1	33	I	C	I ² S-bus I/O	I ² S-bus bit clock input
WSI1	34	I	C		I ² S-bus word select strobe input

ATAPI CD-R block encoder/decoder

SAA7391

SYMBOL	PIN	TYPE	DRIVE/ THRESHOLD	GROUPING	DESCRIPTION
n.c.	35 to 38	–	–	–	not connected
SDI1	39	I	C	I ² S-bus I/O	data input from CD engine
SDO1	40	O	M		data output to CD-R writer
SFSY	41	I/O	L/C	subcode I/O	3-wire subcode sync input/output
RCK	42	I/O	L/C		3-wire subcode clock input/output
SUBI	43	I	C		Q and R-W subcode input
SUBO	44	O	L		subcode output from encoder to writer
CFLG	45	I	C	I ² S-bus input	CD error corrector flags and absolute time sync
C2P0	46	I	C		CD C2 error correction flag input for ERCO
DGND5	47	–	–	–	digital ground 5
IECO	48	O	M	multimedia	IEC 958 output
MCK	49	I/O	M/C	multimedia output	256f _s or 384f _s clock for multimedia master clock/IEC 958 clock or divided system clock for CD-DSP
SCK2	50	I/O	L/C	multimedia	I ² S-bus bit clock input/output
WS2	51	I/O	L/C		I ² S-bus word select strobe input/output
SDO2	52	O	M		I ² S-bus data output to DAC/video decoder
GND	53	–	–	–	ground
CROUT	54	O	crystal pad	crystal oscillator	crystal oscillator output
CRIN	55	I	crystal pad		crystal oscillator/clock input
V _{DDA}	56	–	–	–	analog supply voltage
I _{ref}	57	analog	current input	clock generator	VCO reference current
POR	58	I	Schmitt trigger	system	power-on reset (active LOW)
TEST1	59	I	C	test	mode control input test pins
TEST2	60	I	C		
RESET	61	I	Schmitt trigger	host	ATAPI bus reset input from host (active LOW)
DD7	62	I/O	AL/T	host	data bus input/output
DD8	63	I/O	AL/T		
DD6	64	I/O	AL/T		
V _{DDD(pad1)}	65	–	–	–	digital peripheral supply voltage 1
DGND6	66	–	–	–	digital ground 6
DD9	67	I/O	AL/T	host	data bus pin order of ATAPI interface matches the pinning of the 40-way IDE connector (slew rate limiting by control of drive capability into capacitive load of ATA bus)
DD5	68	I/O	AL/T		
DD10	69	I/O	AL/T		
DD4	70	I/O	AL/T		

ATAPI CD-R block encoder/decoder

SAA7391

SYMBOL	PIN	TYPE	DRIVE/ THRESHOLD	GROUPING	DESCRIPTION
n.c.	71 to 74	–	–	–	not connected
DD11	75	I/O	AL/T	host	data bus; pin order of ATAPI interface matches the pinning of the 40-way IDE connector (slew rate limiting by control of drive capability into capacitive load of ATA bus)
DD3	76	I/O	AL/T		
DD12	77	I/O	AL/T		
DD2	78	I/O	AL/T		
DD13	79	I/O	AL/T		
DD1	80	I/O	AL/T		
DD14	81	I/O	AL/T		
DD0	82	I/O	AL/T		
DD15	83	I/O	AL/T		
DMARQ/ DMACK	84	O	AL	host	DMA request/SCSI DMA acknowledge output (active LOW)
DGND7	85	–	–	–	digital ground 7
V _{DDD(pad2)}	86	–	–	–	digital peripheral supply voltage 2
DIOW	87	I	L/T	host	write cycle write enable/control register write input (active LOW)
DIOR	88	I	L/T	host	read cycle read enable/control register read input (active LOW)
IORDY	89	O	AH	host	device is ready to transfer data output (active LOW)
DMACK/ DMARQ	90	I	T	host	DMA acknowledge (active LOW)/SCSI DMA request input
INTRQ	91		A	host	host interrupt request (NB 3-state output)
DGND8	92	–	–	–	digital ground 8
V _{DDD(pad3)}	93	–	–	–	digital peripheral supply voltage 3
IOCS16	94	O	AH	host	I/O port is 16-bit output (active LOW)
DA1/ <u>DBWR</u>	95	I/O	L/T	host	address wire 1/DMA from generic interface is output from the SAA7391 (active LOW)
PDIAG	96	I/O	AL/T	host	ATAPI passed diagnostics input/output (active LOW)
DA0	97	I/O	L/T	host	address wire 0 input/output
DA2/ <u>DBRD</u>	98	I/O	L/T	host	address wire 2/DMA from generic interface is input to the SAA7391 (active LOW)
<u>CS0</u> / <u>SCSICS</u>	99	I/O	L/T	host	chip select 1FX/generic interface chip select (active LOW)
<u>CS1</u>	100	I/O	L/T	host	chip select 3FX input/output (active LOW)
DASP	101	I/O	AH/T	host	device active slave present input/output (active LOW)
INT2	102	O	L	sub-CPU	sub-CPU interrupt output from the SAA7391 drive block and UART

ATAPI CD-R block encoder/decoder

SAA7391

SYMBOL	PIN	TYPE	DRIVE/ THRESHOLD	GROUPING	DESCRIPTION
DGND9	103	–	–	–	digital ground 9
V _{DDD(pad4)}	104	–	–	–	digital peripheral supply voltage 4
COMACK	105	I	C	UART	command acknowledge/transmit flow control input
COMCLK	106	O	L	UART	serial data clock for synchronous mode output
n.c.	107 to 110	–	–	–	not connected
COMOUT	111	O	L	UART	transmit data output
COMIN	112	I	C	UART	receive data input
COMSYNC	113	I	C	UART	basic engine synchronization input
SYSSYNC	114	I	C	UART	basic engine synchronization input
SCCLK	115	O	M	sub-CPU	sub-CPU clock output
\overline{RD}	116	I	T	sub-CPU	sub-CPU read enable (active LOW)
$\overline{WR/R/W}$	117	I	T	sub-CPU	sub-CPU write enable/and read/write control input (active LOW)
\overline{INT}	118	O	L	sub-CPU	sub-CPU interrupt request output from host interface (active LOW)
SRST	119	O	L	sub-CPU	sub-CPU reset output
SCA0/SCD0	120	I/O	L/T	sub-CPU	multiplexed address/data lines
SCA1/SCD1	121	I/O	L/T		
DGND10	122	–	–	–	digital ground 10
V _{DDD(pad5)}	123	–	–	–	digital peripheral supply voltage 6
SCA2/SCD2	124	I/O	L/T	sub-CPU	multiplexed address/data lines
SCA3/SCD3	125	I/O	L/T		
SCA4/SCD4	126	I/O	L/T		
SCA5/SCD5	127	I/O	L/T		
SCA6/SCD6	128	I/O	L/T		
SCA7/SCD7	129	I/O	L/T		
DGND11	130	–	–	–	digital ground 11
V _{DDD(core2)}	131	–	–	–	digital core supply voltage 2
ALE	132	I	T	sub-CPU	demultiplex enable input for lower address lines
\overline{PSEN}	133	I	T	sub-CPU	program store enable (active LOW)
SCA15	134	I	T	sub-CPU	upper address lines input
SCA14	135	I	T		
SCA13	136	I	T		
SCA12	137	I	T		
DGND12	138	–	–	–	digital ground 12

ATAPI CD-R block encoder/decoder

SAA7391

SYMBOL	PIN	TYPE	DRIVE/ THRESHOLD	GROUPING	DESCRIPTION
SCA11	139	I	T	sub-CPU	upper address lines input
SCA10	140	I	T		
SCA9	141	I	T		
SCA8	142	I	T		
n.c.	143	–	–	–	not connected
n.c.	144	–	–	–	not connected

ATAPI CD-R block encoder/decoder

SAA7391

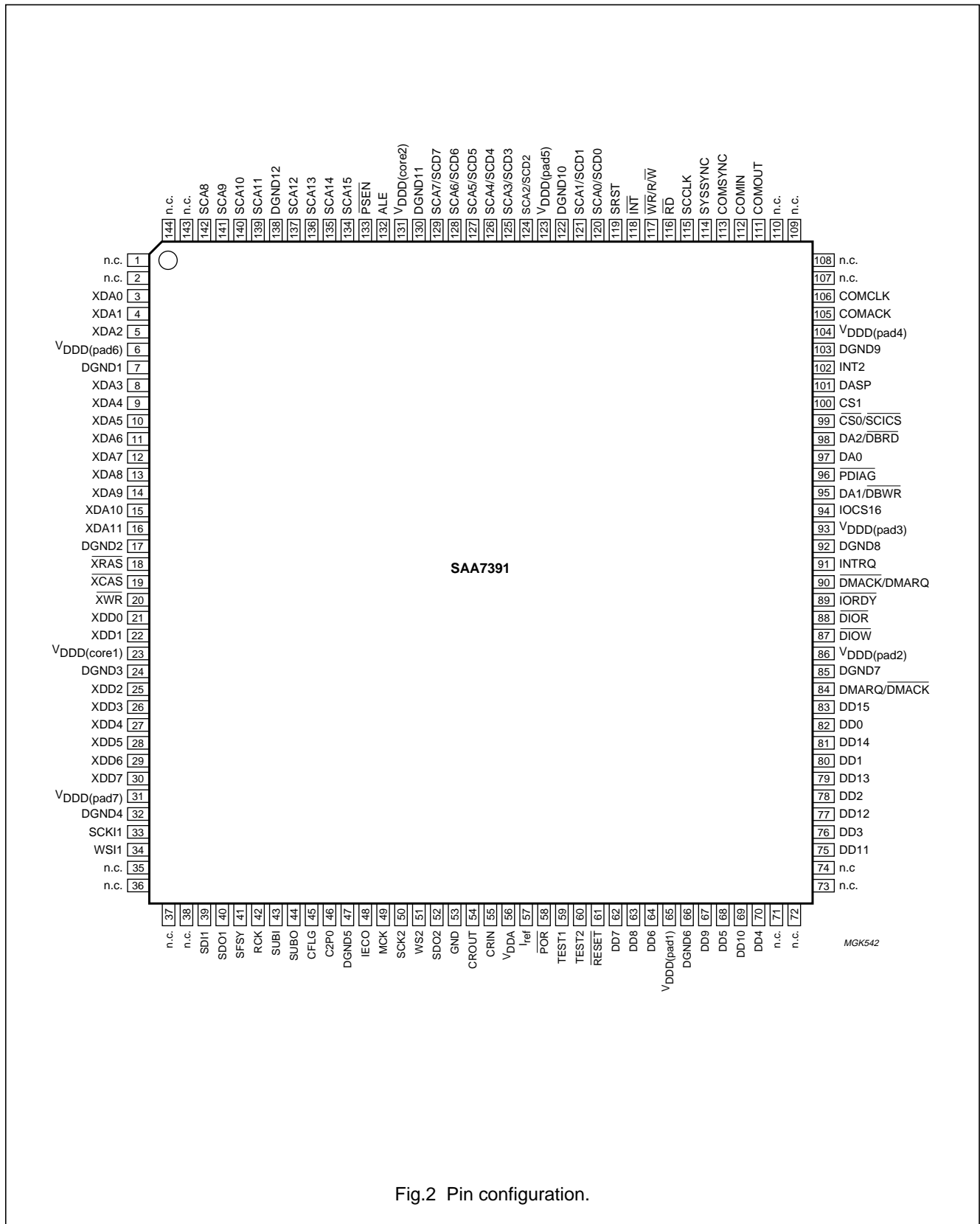

Fig.2 Pin configuration.

ATAPI CD-R block encoder/decoder

SAA7391

6.1 Detailed description of pin functions

Table 1 Q and R-W input/output subcode connections (4 pins)

SYMBOL	DESCRIPTION	COMMENT
SFSY	3-wire subcode sync	input subcode frame sync for receiving 3-wire subcode; output subcode frame sync for transmitting 3-wire subcode
RCK	3-wire subcode clock	output bit clock for receiving 3-wire subcode; input bit clock for transmitting 3-wire subcode
SUBI	Q and R-W subcode input	configurable for 3-wire or Philips V4 subcode mode; can use either RCK or WSI1 as clock references with appropriate dividers
SUBO	output subcode from encode	configurable for Philips SRI (Subcode Recordable Interface) 3-wire or Philips V4 subcode mode; can use either RCK, WSI1 or WS2 as clock references

Table 2 I²S-bus multimedia audio output (5 pins)

SYMBOL	DESCRIPTION	COMMENT
MCK	256f _s or 384f _s clock for multimedia master clock/IEC 958 clock or divided system clock for CD-DSP	Clock reference input pin when interface is in a master mode; a programmable divider is provided. This pin is also configurable as a programmable clock output intended as a clock reference for a CD-DSP. Should be pulled up if not in use.
SCK2	I ² S-bus bit clock	This is used for master and slave I ² S-bus application as both modes are needed. For instance, the Philips multimedia CODEC is an I ² S-bus slave, hence this must be a master interface. When driving some DACs, this interface can be a slave.
WS2	I ² S-bus left/right strobe	word select strobe either master or slave
SDO2	I ² S-bus data to DAC/video decoder	I ² S-bus multimedia data
IECO	IEC 958 output	the IEC 958 output combines multimedia data and Q-W subcode

Table 3 I²S-bus connections to CD engine (6 pins)

SYMBOL	DESCRIPTION	COMMENT
SCKI1	I ² S-bus bit clock	this is a separate clock to the multimedia bit clock as this rate is derived from the disc linear velocity
WSI1	I ² S-bus left/right strobe	
SDI1	I ² S-bus data from CD-DSP	
SDO1	I ² S-bus data to CD-writer	
C2P0	CD C2 error corrector flag from ERCO	these flags are used to indicate errors from second layer correction to the ERCO
CFLG	CD error corrector flags and absolute time sync	The absolute time sync is used in the CD input process for playing 'Red Book' discs; the error corrector status is also read in from this signal, to provide an indication of C1 and C2 performance for CD-RW applications.

ATAPI CD-R block encoder/decoder

SAA7391

Table 4 ATAPI target mode interface

ATAPI NAME	ATAPI MEANING
RESET	ATAPI reset signal: the SAA7391 will not recognize a signal assertion shorter than 20 ns as a valid reset signal.
DD0 to DD7	ATAPI D0 to D7
DD8 to DD15	ATAPI D8 to D15: these data bits are only used in accesses to the 16-bit data port
DMARQ	DMA request: this signal, used for DMA data transfers between host and device, is asserted by the SAA7391 when it is ready to transfer data to or from the host. The direction of data transfer is controlled by DIOR and DIOW.
DMACK	DMA acknowledge: this signal is used by the host in response to DMARQ to initiate DMA transfers. This signal may be temporarily negated by the host to suspend the DMA transfer in process.
IOCS16	ATAPI I/O port is a 16-bit open-drain output: during PIO transfer Modes 0, 1 or 2, IOCS16 indicates to the host system that the 16-bit data port has been addressed and that the device is prepared to send or receive a 16-bit data word.
IORDY	ATAPI I/O ready open-drain output: this signal is negated to extend the host transfer cycle of any host register access (read or write) when the SAA7391 is not ready to respond to a data transfer request. This signal is only enabled during DIOR/DIOW cycles to the SAA7391. When IORDY is not active, it is in the high-impedance (undriven) state.
DA0 to DA2	address bus (device address)
DIOW	ATAPI write strobe: the rising edge of DIOW latches data from the signals, DD0 to DD7 or DD0 to DD15 into a register or the data port of the SAA7391. The SAA7391 will not act on the data until it is latched.
DIOR	ATAPI read strobe: the falling edge of DIOR enables data from a register or data port of the SAA7391 onto the signals, DD0 to DD7 or DD0 to DD15. The rising edge of DIOR latches data at the host and the host will not act on the data until it is latched.
CS0	ATAPI chip select 0 input: this is the chip select signal from the host used to select the ATA command block registers. This signal is also known as CS1FX.
CS1	ATAPI chip select 1 input: this is the chip select signal from the host used to select the ATA control block registers. This signal is also known as CS3FX.
INTRQ	ATAPI interrupt output: this signal is used to interrupt the host system. INTRQ is asserted only when the device has a pending interrupt, the device is selected, and the host has cleared the 'nien' bit in the device control register. If the 'nien' bit is equal to 1, or the device is not selected, this output is in a high-impedance state, regardless of the presence or absence of a pending interrupt.
PDIAG	ATAPI passed diagnostics: this signal shall be asserted by device 1 to indicate to device 0 that it has completed diagnostics.
DASP	ATAPI DASP (device active, device 1 present): this is a time-multiplexed signal which indicates that a device is active, or that device 1 is present. This signal is an open-drain output.

ATAPI CD-R block encoder/decoder

SAA7391

Table 5 Generic host controller interface

ATAPI NAME	GENERIC INTERFACE NAME	GENERIC HOST CONTROLLER INTERFACE MEANING
RESET	RESET	controller reset output
DD0 to DD7	D0 to D7	controller DMA path/controller data and control bus (optional)
DD8 to DD15	D8 to D15	controller upper DMA path (optional)
DMARQ	DMACK	DMA acknowledge to controller
DMACK	DMARQ	DMA request from controller
DA1	DBWR	DMA bus write to controller
DA2	DBRD	DMA bus read from controller
CS0	SCSICS	controller chip select output for sub-CPU read/write cycles

Table 6 Miscellaneous pins

SYMBOL	DESCRIPTION	COMMENT
CRIN	crystal oscillator/clock input	–
CROUT	crystal oscillator output	–
I _{ref}	VCO reference current	clock PLL multiplier
POR	power-on reset pin	–
TEST1 and TEST2	mode control test pins	–

Table 7 Sub-CPU interface pins

SYMBOL	DESCRIPTION	COMMENT
SRST	sub-CPU reset	active HIGH reset if XDD7 is pulled LOW during power-on reset; active LOW reset if XDD7 is pulled HIGH during power-on reset
INT	sub-CPU interrupt request output from host interface	open-drain sub-processor interrupt from host interface
INT2	sub-CPU interrupt output from the SAA7391 drive block and UART	open-drain sub-processor interrupt from drive and UART
SCCLK	sub-CPU clock out	–
RD	sub-CPU read enable	sub-CPU read enable strobe; if grounded permanently, the WR signal will act as read/write control input
WR/R/W	sub-CPU write enable/read/write control	write enable; alternative usage is read/write if RD is held LOW at all times; WR has priority over RD at all times
ALE	demultiplex enable input for lower address lines	while HIGH, the lower address bits are latched from SCD0 to SCD7; should be used with a Schmitt trigger input to avoid false latching due to ground bounce on the 8051 microcontroller

ATAPI CD-R block encoder/decoder

SAA7391

SYMBOL	DESCRIPTION	COMMENT
PSEN	program store enable	if this pin is LOW then the 8051 microcontroller is accessing external program store; this pin is used as an active HIGH chip enable
SCD0 to SCD7/ SCA0 to SCA7	sub-CPU data bus multiplexed/low address bus	–
SCA8 to SCA15	sub-CPU address high bits	–

Table 8 RAM interface pins

SYMBOL	DESCRIPTION	COMMENT
XDA0 to XDA11	RAM address bits, multiplexed for DRAM	up to 16 Mbytes DRAM only supported
$\overline{\text{X}}\text{RAS}$	DRAM row address strobe	
$\overline{\text{X}}\text{CAS}$	DRAM column address strobe	
$\overline{\text{X}}\text{WR}$	RAM write enable	
XDD0 to XDD7	RAM data bus	

Table 9 Basic engine interface

SYMBOL	DESCRIPTION	COMMENT
SYSSYNC	basic engine synchronization input	generate interrupts on rising and/or falling edges
COMSYNC	basic engine synchronization input	generate interrupts on rising and/or falling edges
COMIN	receive data	–
COMOUT	transmit data	–
COMCLK	serial data clock for synchronous mode	–
COMACK	command acknowledge/transmit flow control	must be HIGH for synchronous mode to transmit next data byte

7 FUNCTIONAL DESCRIPTION

The SAA7391 device consists of a number of main functional units; a CD engine interface, a multimedia block, a microcontroller interface, an error detection and correction block, a host interface and a memory manager. There are also several smaller blocks including a clock control block and a UART for communication with the CD engine. Each block is independently controlled by a dedicated register set. These registers are memory mapped to the sub-CPU to allow for faster access. The external RAM can also be accessed directly from the microcontroller to support scratchpad accesses and thus eliminate the need for further memory devices in the system.

7.1 Memory field description

The CD input function of the SAA7391 buffer manager receives the main data stream in I²S-bus format from the CD-DSP, performs sync detection and partitions the data

into blocks. It then writes the blocks to the buffer memory and onboard ERCO RAM. Any detected errors are then corrected and over written into the buffer memory.

Memory is segmented and addressable by segment pointers. The segment pointers consist of a block number, offset pointer and byte number within the block. The data within each segment is organised in the same manner (see Table 10).

The arrangement of data within each segment in memory differs from other Philips devices, because of the different error correction processing possibilities within the SAA7391.

Addresses 0 to 2355 are written to memory by the drive processor when enabled.

ATAPI CD-R block encoder/decoder

SAA7391

Table 10 The memory map of a block in the buffer RAM for standard density mode (see Table 11)

ADDRESS (OFFSET)	TYPE OF DATA
0 to 3	header field
4 to 2339	block data field
2340 to 2351	sync field
2352	copy of STAT0
2353	copy of STAT1
2354	copy of STAT2
2355	number of C2 flags in sector (compressed format)
2356 to 2451	96-byte de-interleaved R-W data field
2452 to 2463	12-byte Q-subcode field
2464 to 2465	copy of STAT4 field; only valid if ERCO did run on this block
2466 to 2559	user work space

Table 11 Description of Table 10

DATA	DESCRIPTION
Header field	The 4-byte header data consists of a 3-byte block address of absolute time (minutes, seconds and frame, bytes 0 to 3). The fourth byte is for the mode of data: Mode 0 = zero mode Mode 1 = data storage with EDC and ECC Mode 2 = data storage
Block data field	in the CD-ROM mode the block data consists of 2048 bytes of user data and 288 bytes of auxiliary data User data: Mode 0= all 2048 bytes in user data are zero Mode 1= all 2048 bytes are available to the user Mode 2= all 2048 bytes are available to the user Auxiliary data: Mode 0= all 288 bytes in Aux data are zero Mode 1= the Aux field is in accordance with the EDC and ECC specification Mode 2= all 288 bytes are available to the user
Sync field	The 12-byte sync field is the next segment in memory. All bytes in the sync field are FFH, except the first and last bytes which are \$00.

ATAPI CD-R block encoder/decoder

SAA7391

DATA	DESCRIPTION
Number of C2 flags in sector (compressed format)	<p>While storage of C2 flag positions is not possible as a consequence of the architecture of the SAA7391, a count of the number of flags seen per block is made in a single-byte counter. This counter packs the possibly 12-bit count into a single byte in the following way, at the expense of resolution in the count values for large counts.</p> <p>$C2count_val = count(5 \text{ down to } 0) \times [4 \wedge count(7 \text{ down to } 6)]$, the resolution of the count is therefore:</p> <p>C2count_val 0 to 63: counter resolution = 1 C2count_val 64 to 255: counter resolution = 4 C2count_val 256 to 1023: counter resolution = 16 C2count_val 1024 to 4095: counter resolution = 64</p>
96-byte de-interleaved R-W data field	<p>Written to memory by the automatic Q-channel copy process (copy2 channel). If the copy process is not enabled, these fields are not written (see Section 7.3.5). These bytes may either be R-W de-interleaved or presented as raw Q-W subcode bytes. If the copy2 interleaving mode is set to raw, interleaved copying is still required as the subcode temporary holding buffer has Q bytes interspersed with the raw R-W.</p>
12-byte Q-subcode field	<p>as above: these will not be separated out if the copy2 interleaving option is set to raw</p>
2 copies of STAT4 field	<p>Address 2465 and 2466 are copies of the STAT4 register written by the ERCO when enabled. This allows the user to determine if the STAT4 register has been written to by the ERCO. If $seg2465 = seg2466$ then STAT4 definitely has not been written by the ERCO. If $seg2465 \neq seg2466$ then STAT4 probably has not been written by the ERCO.</p> <p>Via direct access to buffer memory, the sub-CPU will be able to look at all of the blocks so far corrected, to check their status, in a background task.</p> <p>ERCO failures do not have to be dealt with immediately, as the status of every block loaded in to RAM is stored with that block, and it is not overwritten until the RAM block is filled with new data from CD input.</p> <p>The error corrector will be controlled additionally to permit the use of single pass P-Q or only EDC operation to allow for greater than $n = 14$ operation of the ERCO.</p> <p>The ERCO status will be copied into the RAM along with the data. This is possible because the RAM now has spare capacity to store the information, as part of the change from linear to segment/offset addressing.</p> <p>It is possible to program transfers into RAM of more than one block without processor intervention. It is also possible to continually loop on the same buffer area of RAM, by not altering the reload register values when the reload interrupt occurs.</p>

7.1.1 DVD-ROM MEMORY FIELD INFORMATION

The buffer arrangement for DVD usage is basically the same (data followed by flags) but the size of the block data differs, and the ERCO flags are at a different offset, and as the ERCO is not in use, the flags relating to ERCO performance will not be valid.

ATAPI CD-R block encoder/decoder

SAA7391

7.2 CD input control registers

The CD input process is intended to be as automated as possible. Data is read in from the front end, descrambled if in CD-ROM mode and then written to RAM. The registers that control the address of where the data is written to are in the memory processor block.

The input data is synchronized, decoded and written to the buffer RAM. The input data format is software programmable.

The synchronization is performed by using a sync detector and a sync interpolator. The sync detector can detect CD-ROM syncs and syncs from the CFLG pin, for use with Red Book, audio and for DVD. When no sync is found, it is optionally interpolated.

After decoding, each full sector of data (2352 bytes) comprising sync, header and sub-header is written to the buffer RAM. The R-W and Q subcode is added by a software-initiated automatic block copy process.

7.2.1 REGISTERS ASSOCIATED WITH DATA IN PROCESS

Table 12 IFCONFIG (write only; address FF10H) (see Table 13)

BIT 7	BIT 6	BIT 5	BIT 4	BIT 3	BIT 2	BIT 1	BIT 0
ipconfig	ckdiv1	ckdiv0	subsel	modulo 1	modulo 0	config swap	config wclk

Table 13 Description of the IFCONFIG register bits

BIT	NAME	VALUE	MEANING
7	ipconfig	0	I ² S-bus mode
		1	EIAJ serial interface mode
6 and 5	ckdiv1 and ckdiv0	00	oversample, bit clock division ratio = 2
		01	oversample, bit clock division ratio = 4
		10	oversample, bit clock division ratio = 8
		11	bit clock division ratio = 1 (no division)
4	subsel	0	both copies of sub-header contribute to STAT1/sh0err to sh3err
		1	first copy only of sub-header contributes to STAT1/sh0err to sh3err
3 and 2	modulo 1 and modulo 0	00	modulo count 2352
		01	
		10	modulo count 2064
		11	modulo count 2064, but do not count bytes with flag = 1
1	config swap	0	the received data from the CD-DSP or drive FIFO is not swapped
		1	the received data from the CD-DSP or drive FIFO is swapped
0	config wclk	0	the internal 'irclk' is not inverted
		1	the internal 'irclk' is inverted

ATAPI CD-R block encoder/decoder

SAA7391

Table 14 CD input control registers (see Table 15)

ADDRESS	NAME	BIT 7	BIT 6	BIT 5	BIT 4	BIT 3	BIT 2	BIT 1	BIT 0
FF21H	DRIVECURSEG-L	s7	s6	s5	s4	s3	s2	s1	s0
FF20H	DRIVECURSEG-H	incen	wren	–	s12	s11	s10	s9	s8
FF60H	DRIVECURCOUNT	c7	c6	c5	c4	c3	c2	c1	c0
FF27H	DRIVENEXTSEG-L	s7	s6	s5	s4	s3	s2	s1	s0
FF26H	DRIVENEXTSEG-H	incen	wren	–	s12	s11	s10	s9	s8
FF61H	DRIVENEXTCOUNT	c7	c6	c5	c4	c3	c2	c1	c0
FF23H	DRIVEPREVSEG-L	s7	s6	s5	s4	s3	s2	s1	s0
FF22H	DRIVEPREVSEG-H	incen	wren	–	s12	s11	s10	s9	s8
FF24H	DRIVEOFFSET-H	s7	s6	s5	s4	s3	s2	s1	s0
FF25H	DRIVEOFFSET-L	s7	s6	s5	s4	s3	s2	s1	s0

There are two sets of address registers, one giving the current (DRIVECURSEG) number of the segment being filled and a segment/block counter. The other set contains the values (DRIVENEXTSEG) to use on completion of the current group of blocks being filled or emptied (in CD-R). The DRIVEPREVSEG register is loaded with the value of the DRIVECURSEG register at the end of each CD-ROM block.

The reloading of the registers will trigger an interrupt, if enabled, of the sub-CPU, which will then have to reload the 'next' registers. before the transfer requested in the 'current' registers are exhausted.

Memory is split into segments, each segment is 2560 bytes. The drive data is written one block at a time at the segment number pointed to by the DRIVECURSEG register. For the next block the 'DRIVECURSEG' is updated as follows.

Table 15 Description of the 'incen' and 'wren' bits (see Table 14)

BIT	NAME	VALUE	MEANING
7	incen ⁽¹⁾	0	hold value of DRIVECURSEG
		1	increment DRIVECURSEG at the end of each CD-ROM block received
6	wren ⁽²⁾	0	enable writes of data transferred
		1	disable write of data transferred

Notes

1. If 'incen' is logic 1, the 'DRIVECURSEG' pointer will increment every sector sync. The 'DRIVECURCOUNT' will decrement every sector sync independent of 'incen'. If 'incen' is logic 0 then the pointer will remain fixed pointing at the same segment of RAM. If the reading of data from CD is enabled by the 'wrreq' bit in the CTRL0 register, and the 'wren' bit is logic 0 the segment will be repeatedly filled by the data coming in from the CD-ROM.
2. If 'wren' is logic 1 and 'incen' is logic 1 then the DRIVECURSEG register will increment with each sync time and the DRIVECURCOUNT register will decrement but data will not be written to external RAM. This allows the triggering of the reading of data or the writing of data some time in the future.

Table 16 Control and status registers (see Tables 17, 18 and 19)

ADDRESS	NAME	BIT 7	BIT 6	BIT 5	BIT 4	BIT 3	BIT 2	BIT 1	BIT 0
FF0DH	CTRL0	decen	ahead	e01rq	autoform	eramrq	wrreq	eccrq	encode
FF0EH	CTRL1	syien	syden	asyn	cowren	onepass	–	–	–
FF0FH	CTRL2	modrq	formrq	–	automode	mbckrq	–	dscrlen	–

ATAPI CD-R block encoder/decoder

SAA7391

Table 17 Description of the CTRL0 register bits (resetting the chip sets all the bits in this register to 0)

BIT	NAME	VALUE	DESCRIPTION
7	decen	0	disable decoding, drive in 'full reset' state, no monitor of I ² S-bus line, no interrupts
		1	enable decoding
6	ahead	0	obsolete
		1	must be set to logic 1
5	e01rq	0	disable error correction of bytes for which an error has been detected, but not yet corrected
		1	enable CRC miscorrection correction of the C2 flag bytes
4	autoform	0	disable automatic Form detection
		1	enable automatic Form detection
3	eramrq	0	disable erasure flag use
		1	enable erasure flag use
2	wrreq	0	disable data writes to the buffer and pointer updates, only header and status information recovered
		1	enables data writes to the buffer and pointer updates
1	eccrq	0	disable ECC correction only EDC checking
		1	enable ECC correction, ERCO active
0	encode	0	read operation
		1	perform erasure correction on P and Q check symbols, resulting in encoder operation

Table 18 Description of the CTRL1 register bits (the reset function clears all the flags in this register)

BIT	NAME	VALUE	DESCRIPTION
7	syien	0	disable sync interpolation
		1	enable sync interpolation
6	syden	0	disable sync detection
		1	enable sync detection
5	asyn	0	CD-ROM sync detection
		1	audio sync detection
4	cowren	0	disable rewriting of corrected error bytes
		1	enable rewriting of error bytes during error correction
3	onepass	0	normal error corrector operation
		1	one pass only error correction

ATAPI CD-R block encoder/decoder

SAA7391

Table 19 Description of the CTRL2 register bits

BIT	NAME	VALUE	DESCRIPTION
7	modrq	0	Mode 1 request
		1	Mode 2 request
6	formrq	0	Form 1 request
		1	Form 2 request
4	automode	0	disable automatic determination of mode bit
		1	enable automatic determination of mode bit
3	mbckrq	0	disable mode check function
		1	enable mode check function
1	dscrlen	0	disable descrambling function
		1	enable descrambling function

Table 20 Sub-CPU registers during read (see Tables 21, 22, 23, 27 and 28)

ADDRESS	NAME	BIT 7	BIT 6	BIT 5	BIT 4	BIT 3	BIT 2	BIT 1	BIT 0
FF00H	HEAD0	minutes							
FF01H	HEAD1	seconds							
FF02H	HEAD2	frames							
FF03H	HEAD3	mode							
FF04H	SUBHEAD0	file number							
FF05H	SUBHEAD1	channel number							
FF06H	SUBHEAD2	submode							
FF07H	SUBHEAD3	coding information							
FF08H	STAT0	–	ilsync	nosyn	lblk	–	sblk	erablk	–
FF09H	STAT1	minerr	secerr	blkerr	moderr	sh0err	sh1err	sh2err	sh3err
FF0AH	STAT2	rmod3	rmod2	rmod1	rmod0	mode	form	rform1	rform2
FF0BH	STAT3	valst	–	–	–	–	–	–	–
FF0CH	STAT4	crcok	cblk	uceblk	–	nocor	mode	form	qok

Table 21 Description of the STAT0 register bits (resetting the chip clears all bits in this register)

BIT	NAME	VALUE	DESCRIPTION
7	–	–	reserved
		–	reserved
6	ilsync	0	–
		1	sync pattern detected at word count 0 to 1174
5	nosyn	0	–
		1	sync pattern inserted by sync interpolator not coincident with data sync
4	lblk	0	–
		1	with 'syien' at logic 0, no sync found; data block size has been extended
3	–	–	reserved
		–	reserved

ATAPI CD-R block encoder/decoder

SAA7391

BIT	NAME	VALUE	DESCRIPTION
2	sblk	0	–
		1	short block indication
1	erablk	0	–
		1	one or more bytes of the block are flagged with C2 flags
0	–	–	reserved
		–	reserved

Table 22 Description of the STAT1 register bits; address FF09H (see notes 1 and 2)

BIT 7	BIT 6	BIT 5	BIT 4	BIT 3	BIT 2	BIT 1	BIT 0
minerr ⁽³⁾	secerr ⁽³⁾	blkerr ⁽³⁾	moderr ⁽³⁾	sh0err ⁽⁴⁾	sh1err ⁽⁴⁾	sh2err ⁽⁴⁾	sh3err ⁽⁴⁾

Notes

1. Resetting the chip clears all bits in this register.
2. The bits in this register indicate the reliability of data in the HEAD0 to HEAD3 and SUBHEAD0 to SUBHEAD3 registers.
3. Bits 'minerr', 'secerr', 'blkerr' and 'moderr' indicate errors in the minutes, seconds, frames and mode bytes in the header of the current block.
4. Bits 'sh0err' to 'sh3err' indicate errors in the respective bytes in the subheader.

Table 23 Description of the STAT2 register bits; address FF0AH (see Tables 24, 25 and 26)

BIT 7	BIT 6	BIT 5	BIT 4	BIT 3	BIT 2	BIT 1	BIT 0
rmod3	rmod2	rmod1	rmod0	mode	form	rform1	rform2

Table 24 Description of the 'mode' and 'form' bits

mode	form	SETTING
0	0	Mode 1
1	0	Mode 2, Form 1
X	1	Mode 2, Form 2 or ECC correction impossible

Table 25 Description of the 'rform' bits

rform1	rform2	MEANING
0	0	Form 1
0	1	Form 2
1	X	error in Form byte

ATAPI CD-R block encoder/decoder

SAA7391

Table 26 Description of the 'rmod' bits

rmod3 to rmod30 ⁽¹⁾	MEANING
0000	mode 0
0001	mode 1
0010	mode 2
0011	mode 3
0100	mode 4
0101	mode 5
0110	mode 6
0111	mode 7
1XXX	packet written CD-R, run in/run out, link, XXX is mode
1111	mode = 7 or error in mode byte

Note

- rmod3 = bit 7 #, bit 6 #, bit 5 #, bit 4 #, bit 3 # of C2P0 (where # is logic OR). This is non-zero for packet written CD-R.
 rmod2 = bit 2 # CFLG.
 rmod1 = bit 1 # CFLG.
 rmod0 = bit 0 # CFLG.

Table 27 Description of the STAT3 register bit

BIT	NAME	VALUE	DESCRIPTION
7	valst	0	registers associated with decoder interrupt valid
		1	registers invalid

Table 28 Description of the STAT4 register bits (this register contains the interrupt status on reading)

BIT	NAME	VALUE	DESCRIPTION
7	crcok	0	–
		1	cyclic redundancy check OK
6	cblk	0	–
		1	there has been an error in this block
5	uceblk	0	–
		1	uncorrectable errors in block
4	–	0	reserved
		1	reserved
3	nocor	0	–
		1	ERCO was not started on this block
2	mode	0	Mode 1 used in correcting this block
		1	Mode 2 used in correcting this block
1	form	0	Form 1 used in correcting this block
		1	Form 2 used in correcting this block
0	qok	0	Q channel CRC no error
		1	Q channel CRC error

ATAPI CD-R block encoder/decoder

SAA7391

Table 29 Auxiliary segment pointer

ADDRESS	NAME	BIT 7	BIT 6	BIT 5	BIT 4	BIT 3	BIT 2	BIT 1	BIT 0
FF29H	AUXSEGMENT-L	s7	s6	s5	s4	s3	s2	s1	s0
FF28H	AUXSEGMENT-H	–	–	–	s12	s11	s10	s9	s8

The auxiliary segment pointer points at a group of segments which hold the data FIFOs used in the SAA7391. These are the 'large' FIFOs rather than the small resynchronizing FIFOs inside the SAA7391.

The subcode input/output and $n = 1$ I²S-bus interfaces use these FIFOs (in addition, the shadow debug registers can use some of this space).

The FIFOs are arranged to optimally occupy a contiguous group of segments in the external RAM.

7.3 Multimedia output interface

This block deals with subcode input and output in addition to an audio output which is independent of the I²S-bus input output path connected to the CD-R engine.

Q and R-W subcode features:

- Supports semiautomatic de-interleaving/interleaving
- Subcode sync is aligned with the start of the current block in RAM
- Supports subcode resynchronization when subcode sync is lost
- Supports Philips 'V4' and 3-wire formats (only one RCK and one SFSY pin shared with subcode output)
- Has selectable polarity on RCK
- Uses WS11 pin as timing reference
- Can insert 'P' bit in 3-wire mode via sub-CPU accessible register bit
- Supports regeneration of subcode from IEC 958 output using WS2 as timing reference
- Can accept subcode input while I²S-bus from CD-DSP is oversampled audio at $n = 2$ or $n = 4$ oversample
- Subcode for CD-recordable applications is supported in Philips V4 or 3-wire Philips Subcode Recordable Interface (SRI). This SRI mode is only compatible with CDR60.

Audio output (multimedia) features:

- Has data output for simple audio or digital video for $n = 1$ or $n = 2$ rate regardless of input CD-DSP data rate
- 4096-byte FIFO for audio samples, requires firmware polling for refills using the block copy engine

- Permits CAV and quasi-CLV systems to maintain $n = 1$ audio output
- Basic channel swap, mono-L or mono-R modes, includes muting and L + R summed mono
- IEC 958 output with subcode Q-W for use in CAV and other modes where there is no $n = 1$ clock in the CD-DSP subsystem
 - IEC 958 interface has fully programmable category code and copyright bits for flexibility
 - Subcode on IEC 958 is only available in CD-ROM mode, because the subcode output FIFO is shared.
- Master and slave I²S-bus modes are available
 - IEC 958 is only available when the I²S-bus is in the master mode.
- Can be configured to provide a clock for an external CD-DSP function via the MCK pin
- Can operate in 64f_s or 48f_s I²S-bus modes
- IEC 958 can operate at $n = 2$ although not permitted by standard.

7.3.1 SUBCODE INPUT BLOCK

7.3.1.1 Q-W subcode handling

The subcode data is initially converted from serial-to-parallel format and is then handled as Q-W bytes.

The de-interleaving is performed by a de-interleaving block copy mode in the memory processor's block copy engine. Subcode blocks will always be aligned with a block of CD-ROM data, although the subcode Minutes, Seconds, Frames (MSF) absolute time may have an uncertainty of ± 5 frames in terms of the actual CD-ROM block it is referring to. This offset is unknown but consistent in any given application. The block copy engine will be automatically triggered when the subcode synchronization is found.

The error corrector will then compute the CRC syndrome of the subcode and deposit it in the CRC bytes. The sub-CPU will have to perform the actual correction if a non-zero syndrome appears.

This syndrome, if calculated during encoding by the ERCO, can be used as the CRC written to disc for the subcode.

ATAPI CD-R block encoder/decoder

SAA7391

7.3.1.2 Description of subcode interface

The subcode interface allows the reception and transmission of subcodes. The subcodes will be received/transmitted to two on-chip 512-byte FIFOs, one for transmit and one for receive. No interrupts are associated with these FIFOs as the block copy engine removes data or fills these as necessary.

There is, however, an interrupt which is asserted when a sync is found in an unexpected location.

7.3.2 SUBCODE MODE TRANSMIT CONTROL REGISTER

Table 30 Subcode mode transmit control register (SUBMODETX; address FF13H); see Table 31

BIT 7	BIT 6	BIT 5	BIT 4	BIT 3	BIT 2	BIT 1	BIT 0
–	–	–	pbit	–	txena	–	V4

Table 31 Description of the SUBMODETX register bits

BIT	NAME	VALUE	DESCRIPTION
4	pbit	0	P bit logic 1 in 3-wire mode (default)
		1	P bit logic 0 in 3-wire mode
2	txena	0	subcode transmit interface is disabled
		1	subcode transmit interface is enabled
0	V4	0	Philips SRI 3-wire subcode
		1	Philips V4 mode; note 1

Note

- Philips V4 subcode transmit mode must be selected for correct insertion of subcode into the IEC 958 data stream.

For CD-recordable applications with CDR60 the Philips SRI subcode mode allows for correct subcode frame synchronization between the SAA7391 and the CDR60 device before recording commences.

Table 32 Subcode mode receive control register (SUBMODERX, address FF17H); see Table 33

BIT 7	BIT 6	BIT 5	BIT 4	BIT 3	BIT 2	BIT 1	BIT 0
–	–	–	wdiv1	wdiv0	rxena	rckinrx	rxsubqw

Table 33 Description of the SUBMODERX register bits

BIT	NAME	VALUE	DESCRIPTION
4	wdiv1	00	no oversampling (normal CD-ROM modes)
		01	2 times oversampling
3	wdiv0	10	4 times oversampling
		11	8 times oversampling
2	rxena	0	subcode receive interface is disabled
		1	subcode receive interface is enabled
1	rckinrx	0	normal RCK output
		1	invert the RCK output
0	rxsubqw	0	3-wire subcode
		1	Philips V4 mode (sub Q-W)

ATAPI CD-R block encoder/decoder

SAA7391

Table 34 Subcode general (input/output pointers)

ADDRESS	NAME	BIT 7	BIT 6	BIT 5	BIT 4	BIT 3	BIT 2	BIT 1	BIT 0
FF2BH	SUBPOINTR-L	s7	s6	s5	s4	s3	s2	s1	s0
FF2AH	SUBPOINTR-H	–	–	–	–	–	–	–	s8
FF2FH	SUBPOINTW-L	s7	s6	s5	s4	s3	s2	s1	s0
FF2EH	SUBPOINTW-H	–	–	–	–	–	–	–	s8
FF2DH	SUBBASEPOINTR-L	s7	s6	s5	s4	s3	s2	s1	s0
FF2CH	SUBBASEPOINTR-H	–	–	–	–	–	–	–	s8
FF31H	SUBBASEPOINTW-L	s7	s6	s5	s4	s3	s2	s1	s0
FF30H	SUBBASEPOINTW-H	–	–	–	–	–	–	–	s8

7.3.2.1 Subcode buffering

The subcode is buffered in the AUXSEGMENT register. Two offset pointers, SUBPOINTR-L and SUBPOINTR-H, and SUBPOINTW-L and SUBPOINTW-H are associated with it. The R pointer is for the subcode output and the W pointer for the subcode input.

Pointers are also provided to point at the offset into the AUXSEGMENT register where the start of a subcode frame will be found, SUBBASEPOINTR-L and SUBBASEPOINTR-H and SUBBASEPOINTW-L and SUBBASEPOINTW-H. The block copy engine is expected to use these to automatically move the subcode into the segment pointed at by DRIVECURSEG register.

7.3.3 GENERAL DESCRIPTION OF THE MULTIMEDIA OUTPUT INTERFACE**Table 35** Multimedia output interface register bits

ADDRESS	NAME	BIT 7	BIT 6	BIT 5	BIT 4	BIT 3	BIT 2	BIT 1	BIT 0
FF32H	CDDA-H	–	–	–	–	–	–	a9	a8
FF33H	CDDA-L	a7	a6	a5	a4	a3	a2	a1	a0
FF34H	DAOFFSET-H	–	–	–	–	a11	a10	a9	a8
FF35H	DAOFFSET-L	a7	a6	a5	a4	a3	a2	a1	a0
FF16H	MMCTRL ⁽¹⁾	mmdiv				spdx2	wslen	mcksel	
FF70H	IECTRL ⁽²⁾	iecen	data	copyright	preem	vbit	–	accu	
FF71H	IECCAT	cat7	cat6	cat5	cat4	cat3	cat2	cat1	cat0
FF14H	MMAUD ⁽³⁾	daen	eiaj	master	–	leftmode		rightmode	
FF15H	MCK_CON ⁽⁴⁾	–	–	–	–	mckxtal	mckoe	div	

Notes

1. See Table 36.
2. See Table 39.
3. See Table 38.
4. See Table 41.

ATAPI CD-R block encoder/decoder

SAA7391

7.3.3.1 Basic description of the multimedia output interface

The multimedia data output may be used either with an internal clock or an externally provided clock. The clock used should be a correct multiple of 44100 Hz in order for the block to correctly output IEC 958.

The multimedia interface data FIFO is located in the block of segments associated with AUXSEGMENT master/slave mode operation (see Fig.3).

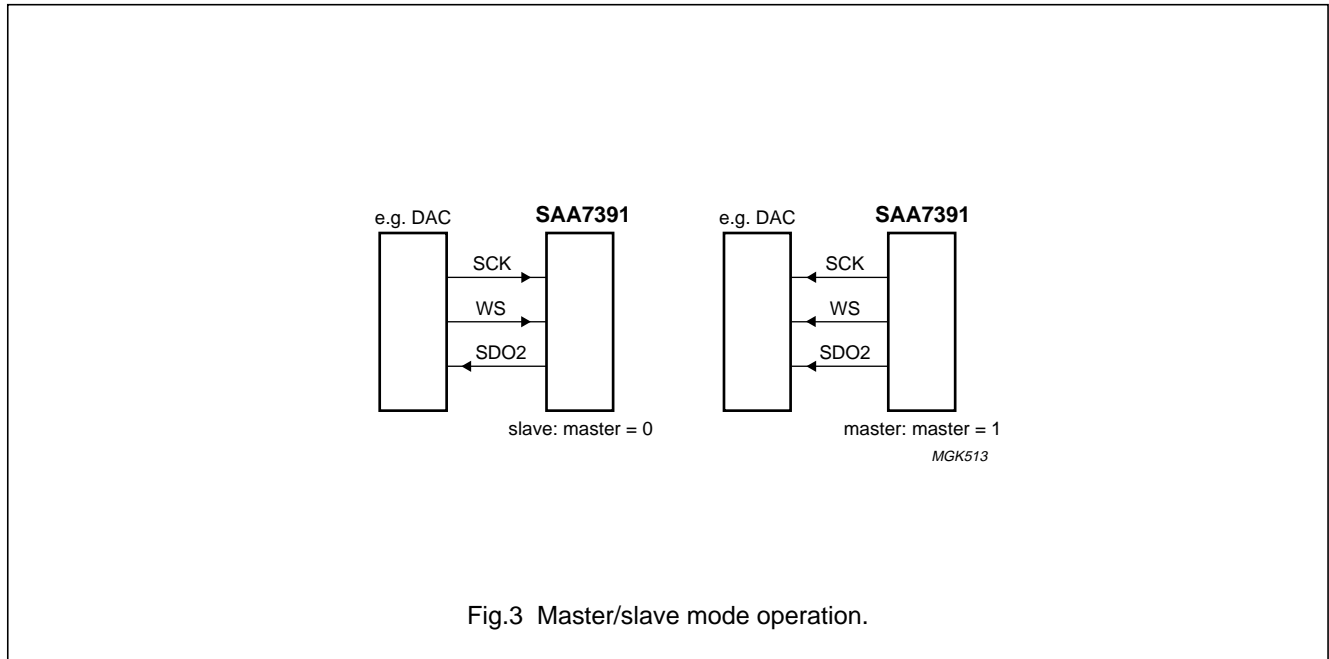

Fig.3 Master/slave mode operation.

Table 36 Description of the MMCTRL register bits

BIT	NAME	VALUE	DESCRIPTION
7	mmdiv	–	see Table 37
6		–	
5		–	
4		–	
3	spdx2	0	I ² S-bus output is single speed
		1	I ² S-bus (and IEC 958) output is double speed; video applications
2	wslen	0	I ² S-bus bit clock is 64 times the sample rate
		1	I ² S-bus bit clock is 48 times the sample rate
1 and 0	mcksel	00	multimedia internal clock is CRIN pin
		01	multimedia internal clock is MCK pin
		10	multimedia internal clock is system clock

ATAPI CD-R block encoder/decoder

SAA7391

Table 37 mmdiv/mcksel relationship to clocks needed for I²S-bus and IEC 958

DIVIDER CODE mmdiv	mcksel		I ² S-BUS OUTPUT				IEC 958	
			I ² S-BUS, 48 BITS PER SAMPLE		I ² S-BUS, 64 BITS PER SAMPLE			
	MULTIMEDIA CLOCK OVERSAMPLE	FREQUENCY (Hz)	n = 1	n = 2	n = 1	n = 2	n = 1	(n = 2)
0000	48f _s	2116800	1 ⁽¹⁾	–	–	–	–	–
0001	64f _s	2822400	–	–	1 ⁽¹⁾	–	–	–
0010	96f _s	4233600	2	1 ⁽¹⁾	1.5 ⁽¹⁾	–	–	–
0011	128f _s	5644800	–	–	2	1 ⁽¹⁾	1	–
0100	192f _s	8467200	4	2	3	1.5 ⁽¹⁾	1.5	–
0101	256f _s	11289600	–	–	4	2	2	(1)
0110	384f _s	16934400	8	4	6	3	3	(1.5) ⁽²⁾
0111	512f _s	22579200	–	–	8	4	4	(2)
1000	768f _s	33868800	16	8	12	6	6	(3)
1001	1024f _s	45158400	–	–	16	8	8	(4)
1010	1536f _s	67737600	32	16	24	12	12	(6)

Notes

- For these combinations the duty factor of the output SCK2 clock is not necessarily 50%. These combinations are therefore not recommended.
- This is illegal but possible.

Table 38 Description of the MMAUD register control bits

BIT	NAME	VALUE	DESCRIPTION
7	daen ⁽¹⁾	0	CD-DA interface is off
		1	CD-DA Interface is on
6	eiaj	0	I ² S-bus serial mode
		1	EIAJ16 serial mode
5	master	0	I ² S-bus is slave
		1	I ² S-bus is master
3	leftmode	00	I ² S-bus left channel output is left (default)
		01	I ² S-bus left channel output is right
2		10	I ² S-bus left channel output is muted
		11	reserved
1	rightmode	00	I ² S-bus right channel output is right (default). This is the opposite default to left channel.
		01	I ² S-bus right channel output is left
0		10	I ² S-bus right channel output is muted
		11	reserved

Note

- If enabled, data is written to the CDDA interface from a FIFO located in the CDDA register space. If either 'daen' = 1 or 'iecen' = 1 (ieccrtl), the interface will become active.

ATAPI CD-R block encoder/decoder

SAA7391

7.3.4 IEC 958/EBU OUTPUT

Table 39 Description of the IECCTRL register control bits (notes 1 and 2)

BIT	NAME	VALUE	DESCRIPTION
7	iecen	0	IEC 958 interface is off
		1	IEC 958 Interface is on
6	data	0	IEC 958 contains audio information
		1	IEC 958 contains data
5	copyright	0	IEC 958 C bit in system channel is logic 0
		1	IEC 958 C bit in system channel is logic 1
4	preem	0	audio pre-emphasis off/IEC 958 contains data
		1	audio pre-emphasis on (only appears in IEC 958 C channel; de-emphasis bit is not implemented in the SAA7391)
3	vbit	0	audio samples suitable for conversion
		1	mute audio, or signal is data and should not be digital-to-analog converted at any time
2	-	-	reserved
		-	reserved
1 to 0	accu	00	level II clock accuracy
		01	level III clock accuracy (depends on mck/system clock)
		10	reserved
		11	reserved

Notes

1. In order for the IEC interface to operate correctly, it will require a clock at $128f_s$ to be present.
2. The 'vbit' is copied into the V bit of the IEC 958 frame.

Table 40 IEC 958 system channel bit mapping (note 1)

BIT NUMBER	BIT OFFSET							
	+0	+1	+2	+3	+4	+5	+6	+7
0	0	data	copyright	preem	-	0	0	0
8	cat0	cat1	cat2	cat3	cat4	cat5	cat6	cat7
16	0	0	0	0	0	0	0	0
24	0	0	0	0	accu0	accu1	0	0

Note

1. The C bit is updated on an IEC frame-by-frame basis, the bit offset corresponds to the IEC frame offset. They are repeated for both left and right channels. Bit 0 is present in the C bit of the first sample pair of the IEC superframe of 192 sample pairs.

ATAPI CD-R block encoder/decoder

SAA7391

Table 41 Description of the MCK_CON register bits (note 1)

BIT	NAME	VALUE	DESCRIPTION
3	mckxtal	0	MCK reference is system clock (default)
		1	MCK reference is the CRIN pin
2	mckoe	0	MCK pin is 3-state, an input to the MM block (default)
		1	MCK pin is output
1 and 0	div	00	MCK reference is divided by 2 (default)
		01	MCK reference is divided by 1.5
		10	MCK reference is divided by 1
		11	MCK reference is divided by 4

Note

- The bits in this register control the use of the MCK pin as an output to clock a CD-DSP. The division ratios chosen are suitable for the SAA7335 or CDR60 devices. If the MCK pin is not being used then it should be pulled HIGH for correct selection of the internal multimedia clocks.

7.3.5 MEMORY-TO-MEMORY BLOCK COPY FUNCTION

This function is provided for the user to move and copy blocks of RAM. Two pointer sets are provided. The second of these is for the semi-automatic subcode copying function of the subcode in the block. It is independent of the first copy register set, which is available for e.g. audio copying needed in the PLAY AUDIO function with the SAA7391, and for subcode copying when recording.

When started, the copy process will copy the COPYCOUNT register bytes from the 'FROM' pointers to the 'TO' pointers. A copying process may be stopped during its operation by writing to the 'copyend' bit.

7.3.5.1 Automatic copying of received subcode-to-data block

When enabled, the newly received subcode will be automatically transferred to the current host segment in RAM.

The only register that is user programmable in the subcode copying engine is the COPYFROM2OFFSET pointer.

The 'COPYFROM2OFFSET' pointer is set up by the sub-CPU to point into the subcode input FIFO. It points at the first byte of subcode to be copied into the current host data block. Once triggered, this copy is automatically set-up to correctly transfer the next block of subcode correctly without host intervention.

Copying of the subcode in the opposite direction is performed by the sub-CPU commanding an interleaved copy of data using the user block copy registers. This does not have to be as fast as the recorder function is only specified to $n \geq 8$. Hence it is not automated.

ATAPI CD-R block encoder/decoder

SAA7391

Table 42 Block copy registers

ADDRESS	NAME	BIT 7	BIT 6	BIT 5	BIT 4	BIT 3	BIT 2	BIT 1	BIT 0
FF67H	COPYCONTROL ⁽¹⁾	dfrom	dto	dfrom2	dto2	en1	en2	raw	sub_deint_order
FF3BH	COPYFROMSEG-L	s7	s6	s5	s4	s3	s2	s1	s0
FF3AH	COPYFROMSEG-H	–	–	–	–	s11	s10	s9	s8
FF37H	COPYFROMOFFSET-L	a7	a6	a5	a4	a3	a2	a1	a0
FF36H	COPYFROMOFFSET-H	–	–	–	–	a11	a10	a9	a8
FF3DH	COPYTOSEG-L	s7	s6	s5	s4	s3	s2	s1	s0
FF3CH	COPYTOSEG-H	–	–	–	–	s11	s10	s9	s8
FF39H	COPYTOOFFSET-L	a7	a6	a5	a4	a3	a2	a1	a0
FF38H	COPYTOOFFSET-H	–	–	–	–	a11	a10	a9	a8
FF63H	COPYCOUNT-L	c7	c6	c5	c4	c3	c2	c1	c0
FF62H	COPYCOUNT-H	–	–	–	–	c11	c10	c9	c8
FF3FH	FROM2OFFSET-L	a7	a6	a5	a4	a3	a2	a1	a0
FF3EH	FROM2OFFSET-H	–	–	–	–	a11	a10	a9	a8
FF41H	TO2OFFSET-L	a7	a6	a5	a4	a3	a2	a1	a0
FF40H	TO2OFFSET-H	–	–	–	–	a11	a10	a9	–

Note

1. See Table 43.

Table 43 Description of the COPYCONTROL register bits

BIT	NAME	VALUE	DESCRIPTION
7	dfrom	0	linear addressing with COPYOFFSET
		1	interleaved addressing with COPYOFFSET
6	dto	0	linear addressing with COPYTOOFFSET
		1	interleaved addressing with COPYTOOFFSET
5	dfrom2	0	linear addressing in copy from block, subcode copy engine
		1	interleaved addressing in copy to block, subcode copy engine
4	dto2	0	linear addressing in copy to block, subcode copy engine
		1	interleaved addressing in copy to block, user block copy engine
3	en1	0	user block copy disabled
		1	user block copy enabled
2	en2	0	subcode block copy disabled
		1	subcode block copy enabled
1	raw	0	enable complete subcode de-interleaving process
		1	de-interleave R-W bytes, but skip Q byte de-interleaving
0	sub_deint_order	0	de-interleave received subcode (CD-ROM)
		1	Interleave transmitted subcode (CD-R)

ATAPI CD-R block encoder/decoder

SAA7391

7.4 Interrupt registers

The interrupt system in the SAA7391 is intended to make it possible to acknowledge interrupts both independently without interference or together. There are two interrupt pins to the sub-CPU from the SAA7391. The $\overline{\text{INT}}$ pin is associated only with the host interface register IFSTAT (address FF92H). The INT2 pin is associated with 6 interrupt registers which cover the SAA7391 drive block and UART. Two status/reset registers and two interrupt enable register for the drive block and one status/reset register plus an interrupt enable register for the UART.

Table 44 IFSTAT interrupt register for the host interface; address FF92H (note 1)

ACCESS	BIT 7	BIT 6	BIT 5	BIT 4	BIT 3	BIT 2	BIT 1	BIT 0
R	$\overline{\text{cmdi}}$	$\overline{\text{dtei}}$	$\overline{\text{drqi}}$	$\overline{\text{ultra_stop}}$	dtbsy	srsti	$\overline{\text{reset08}}$	$\overline{\text{a0comp/}}$ $\overline{\text{crc_error}}$

Note

1. Interrupt status bits are described in the host interface; see Section 7.5.3.18.

7.4.1 INTERRUPT 1

By writing a logic 1 to the INT1RESET register the bits will negate the INT1STATUS register bits. Writing a logic 1 to an INT1ENABLE bit will enable the corresponding status bit. Writing a logic 0 will disable the status to zero.

Table 45 INT1STATUS: drive interrupt register status; address FF7AH (see Table 54)

ACCESS	BIT 7	BIT 6	BIT 5	BIT 4	BIT 3	BIT 2	BIT 1	BIT 0
R	dec	nocor	erablk	cblk	uceblk	crc-ng	q-ng	int2

Table 46 INT1RESET: drive interrupt register reset; address FF7AH (see Table 54)

ACCESS	BIT 7	BIT 6	BIT 5	BIT 4	BIT 3	BIT 2	BIT 1	BIT 0
W	dec	nocor	erablk	cblk	uceblk	crc-ng	q-ng	–

7.4.1.1 INT1ENABLE: drive interrupt register enable bits

Table 47 INT1ENABLE: drive interrupt register enable; address FF7BH (see Table 54)

ACCESS	BIT 7	BIT 6	BIT 5	BIT 4	BIT 3	BIT 2	BIT 1	BIT 0
W	dec	nocor	erablk	cblk	uceblk	crc-ng	q-ng	int2

ATAPI CD-R block encoder/decoder

SAA7391

7.4.2 INTERRUPT 2

By writing a logic 1 to INT2RESET register bits will negate the INT2STATUS bit. Writing a logic 1 to an INT2ENABLE bit will enable the corresponding status bit. Writing a logic 0 will disable the status to zero.

Table 48 INT2STATUS: drive interrupt register status; address FF7CH (see Table 54)

ACCESS	BIT 7	BIT 6	BIT 5	BIT 4	BIT 3	BIT 2	BIT 1	BIT 0
R	hostbyte countzero	drive reload	hostrel countzero	copyend	subcode syncint	dmatxint	int1	uartint

Table 49 INT2RESET: drive interrupt register reset; address FF7CH (see Table 54)

ACCESS	BIT 7	BIT 6	BIT 5	BIT 4	BIT 3	BIT 2	BIT 1	BIT 0
W	hostbyte countzero	drive reload	hostrel countzero	copyend	subcode syncint	dmatxini	–	–

Table 50 INT2ENABLE: drive interrupt register enable; address FF7DH (see Table 54)

ACCESS	BIT 7	BIT 6	BIT 5	BIT 4	BIT 3	BIT 2	BIT 1	BIT 0
W	hostbyte countzero	drive reload	hostrel countzero	copyend	subcode syncint	dmatxini	–	–

7.4.3 UART INTERRUPT

By writing a logic 1 to the INT2RESET register bits will negate the INT2STATUS bit. Writing a logic 1 to an INT2ENABLE bit will enable the corresponding status bit. Writing a logic 0 will disable the status to zero.

The INT2 interrupt corresponds to not (INT1 or INT2 or UARTINT).

Table 51 UARTINTSTATUS: UART interrupt register status; address FF78H (see Table 54)

ACCESS	BIT 7	BIT 6	BIT 5	BIT 4	BIT 3	BIT 2	BIT 1	BIT 0
R	comsync	syssync	notcomsync	notsyssync	nottxbfull	rxbfull	overrun	rxparity

Table 52 UARTINTRESET: UART interrupt register reset; address FF78H (see Table 54)

ACCESS	BIT 7	BIT 6	BIT 5	BIT 4	BIT 3	BIT 2	BIT 1	BIT 0
W	comsync	syssync	notcomsync	notsyssync	nottxbfull	rxbfull	overrun	rxparity

Table 53 UARTINTENABLE: UART interrupt register enable; address FF79H (see Table 54)

ACCESS	BIT 7	BIT 6	BIT 5	BIT 4	BIT 3	BIT 2	BIT 1	BIT 0
W	comsync	syssync	notcomsync	notsyssync	nottxbfull	rxbfull	overrun	rxparity

ATAPI CD-R block encoder/decoder

SAA7391

Table 54 Description of the interrupt register bits

REGISTER	INTERRUPT	DESCRIPTION
INTERRUPT 1	dec	block by block decoder interrupt
	nocor	ERCO cannot be started on current block
	erablk	one or more bytes coming from CD-DSP have been flagged with error
	cblk	corrected current block.
	uceblk	one or more bytes remain in error
	crc-ng	bad CRC on current block
	q-ng	bad Q CRC on current block
INTERRUPT 2	int2	indicates that interrupt is caused by an enabled interrupt from INT2
	hostbytecountzero	the host counter decremented to zero and may have been reloaded; requires sub-CPU intervention when reload is disabled
	drivereload	drive processing pointers have reloaded
	hostcurscgcntzero	the host reload count decremented to zero; no more host reloads are available
	copyend	copy process has finished
	subcode syncint	subcode receive block detection of early subcode 98 frame sync period
	dmatxint	asserts when 'dmacount' reaches zero with 'dmaon' bit set
UART INT	int1	indicates that interrupt is caused by an enabled interrupt from INT1
	uartint	indicates that the interrupt is from the UART interrupt register
	comsync	UART COMSYNC pin rising edge interrupt
	syssync	SYSSYNC pin rising edge interrupt
	notcomsync	COMSYNC falling edge interrupt
	notsyssync	SYSSYNC pin falling edge interrupt
	nottxbfull	transmit buffer has become empty
rxbfull	receive buffer has become full	
overrun	receive buffer has overrun	
	rparity	a character has been received with illegal parity

7.5 Host interface

7.5.1 INTRODUCTION

The SAA7391 host interface block is responsible for the transfer of data and control information between the memory processor, external host and microcontroller. The host interface operates in conjunction with the SAA7391 Auxiliary block (Aux block). The Aux block contains several registers that automate the SAA7391 memory processor in its task of supplying the host interface with data from the buffer memory and receiving data from the host interface to be placed in the buffer memory. The host interface automates data transfer to and from the host, whereas the Aux block automates data transfer, via the memory processor and buffer memory, depending on the CD format.

The host interface features are as follows:

- Supports ATA Packet Interface (ATAPI revision 2.6) for CD-ROMs
- Supports ATA/ATAPI 16-bit PIO data transfers for Modes 0, 1, 2, 3 and 4
- Supports ATA/ATAPI single/multi word DMA transfers for Modes 0, 1 and 2
- Supports ultra DMA for Mode 0
- Supports generic interface connection to external SCSI controller device (NCR 53CF92)
- Command and status registers of external generic interface controller are optionally mapped via the host interface pins of the SAA7391. the SAA7391 becomes the bus master.
- Operates automatically with multi-block host data transfers

ATAPI CD-R block encoder/decoder

SAA7391

- Reduces microcontroller load in simple streaming transfers to or from host using a circular buffer
- Recognizes ATA SRST, the ATAPI reset command (0X08) and the ATAPI packet command (0XA0) and handles these automatically in ATAPI mode
- Handles unexpected ATA commands during PIO data transfers
- Provides automatic DRQ for all PIO data transfers
- Provides automatic detection of ATAPI packet (A0) command and reception of the packet bytes
- Provides automatic completion sequence for PIO DMA and ultra DMA transfers
- Supports shadowing of registers for single drive configurations with non-existent slave.

7.5.2 DESCRIPTION OF THE HOST INTERFACE BLOCK

The host interface block consists of three FIFOs which can be configured by the DTCTR register to generate the required data path through the host interface block. The design supports ATAPI (revision 2.6) for CD-ROM interfaces.

7.5.2.1 The SAA7391 host interface ATAPI registers visible to the host

Table 55 Host interface registers as seen from the host (note 1)

CS0	CS1	DA2	DA1	DA0	HOST READ ($\overline{\text{DIOR}}$)	HOST WRITE ($\overline{\text{DIOW}}$)
1	0	1	1	0	ALT STATUS: alternative status	ADCTRL: ATAPI device control
1	0	1	1	1	ADRADR: ATAPI drive address	not used
0	1	0	0	0	DATA: data register	DATA: data register
0	1	0	0	1	AERR: ATAPI error register	AFEAT: ATAPI features register
0	1	0	0	1	SHERR: ATAPI error register (shadow)	unused
0	1	0	1	0	AINTR: ATAPI interrupt reason register	unused
0	1	0	1	1	ASAMT: ATAPI SAM TAG register	ASAMT: ATAPI SAM TAG register
0	1	1	0	0	DBCL: ATAPI byte count low	DBCL: ATAPI byte count low
0	1	1	0	1	DBCH: ATAPI byte count high	DBCH: ATAPI byte count high
0	1	1	1	0	ADRSEL: ATAPI drive select register	ADRSEL: ATAPI drive select register
0	1	1	1	1	ASTAT: ATAPI status register	ACMD: ATAPI command register
0	1	1	1	1	SHSTAT: ATAPI status register (shadow)	unused

Note

1. The operation of these registers complies with the ATA-3 specification (revision 6) and the ATAPI specification (revision 2.6).

The host interface has a shadow status register to permit proper ATA operation. The $\overline{\text{PDIAG}}$ and $\overline{\text{DASP}}$ signals are controlled by the register bits in the host interface block.

The microcontroller has access to all registers in the host interface block. The microcontroller can control all operations required for data transfer to and from the host, but may configure the host interface sequencer to automate the following three operations:

1. Automation of detection of the A0 packet command and reception of the 12-byte packet.
2. Automation of the data transfer sequences for PIO, DMA and ultra DMA modes of data transfer.
3. Automation of completion sequences for PIO, DMA and ultra DMA modes of data transfer.

The host interface provides a generic interface mode for a glueless connection to an external SCSI controller device. In this mode the microcontroller can configure the registers of the SCSI controller device and initiate DMA transfers.

ATAPI CD-R block encoder/decoder

SAA7391

7.5.2.2 The SAA7391 host interface registers visible by the microcontroller

The registers listed in Table 56 are used by the microcontroller to control the operation of the host interface block. The ATAPI command block registers (ADATA, ASTAT, ADRADR, ASAMT, ADRSEL, AINTR, AERR, ACMD, ADCTR, AFEAT and APCMD) are dual port registers which can be accessed either by the microcontroller or the host PC depending the state of the BSY flag, bit 7 of the ASTAT register.

Table 56 Host registers as seen by the microcontroller

ADDR	ACCESS	NAME	BIT 7	BIT 6	BIT 5	BIT 4	BIT 3	BIT 2	BIT 1	BIT 0	
FF80H	W	ADATA	ATAPI Data register								
FF81H	RW	IFCTRL	cmdien	dteien	drqien	ultra_stopien	–	srstien	–	–	
FF82H	RW	DBCL	Data Byte Count register (bits 7 to 0)								
FF83H	RW	DBCH	Data Byte Count register (bits 15 to 8)								
FF84H	W	DTRG	Data transfer Trigger register								
FF85H	W	DTACK	Data Transfer Acknowledge register								
FF86H	W	RESET	reserved					hsel			
FF87H	RW	ASTAT	ATAPI Status register (see Table 61)								
FF88H	W	ITRG	host Interrupt Trigger register								
FF89H	W	ADRADR	ATAPI Drive Address register								
FF8AH	RW	ASAMT	ATAPI SAM tag register								
FF8BH	RW	DTCTR	reserved	dmamode	dma	ultra_dma	rdrv	trant			
FF8CH	RW	ADRSEL	ATAPI Drive Select register								
FF8DH	RW	AINTR	ATAPI Interrupt Reason register								
FF8EH	RW	AERR	ATAPI Error Register								
FF8FH	R	ACMD	ATAPI Command register								
FF90H	R	ADCTR	ATAPI Device Control Register								
FF91H	R	AFEAT	ATAPI Features register								
FF92H	RW	IFSTAT	cmdi	dtei	drqi	ultra_stop	dtbsy	srsti	reset08	a0comp/ crc_error	
FF93H	R	APCMD	ATAPI Packet Command register								
FF94H	RW	HICONF0	ultractrl2 to ultractrl0			dynhosthiprior		hrequest		shadow	
FF95H	RW	HICONF1	dmaen	shhpbbit	udmaoff	flushfifo	–	unmaskdtie	clear_reg	ultractrl3	
FF96H	RW	HISEQ	autoa0	autodrq	comp	error	sus_seq	repeat autoA0	–	–	
FF97H	RW	SHSTAT	0	0	0	0	0	0	0	shcheck	

ATAPI CD-R block encoder/decoder

SAA7391

ADDR	ACCESS	NAME	BIT 7	BIT 6	BIT 5	BIT 4	BIT 3	BIT 2	BIT 1	BIT 0
FF98H	RW	SHERR	0	0	0	0	0	shabrt	0	0
FF99H	RW	HIDEV	pdiag out	pdiag pad enable	dasp out	dasp pad enable	pdiag in	dasp in	–	hosthipi
FF9AH	R	HISTAT	not used							
FFA0H	RW	TRANSFER COUNTER	byte count (bits 7 to 0)							
FFA1H	RW	TRANSFER COUNTER	byte count (bits 15 to 8)							
FFA2H	RW	TRANSFER COUNTER	byte count (bits 23 to 16)							
FFA3H	RW	TRANSFER COUNTER	byte count (bits 31 to 24)							
FFA4H	RW	PACKETSIZE STORE	byte count (bits 7 to 0)							
FFA5H	RW	PACKETSIZE STORE	byte count (bits 15 to 8)							
FFA6H	R	SEQUENCER _STATUS	–	–	sequence state (bits 5 to 0)					

ATAPI CD-R block encoder/decoder

SAA7391

7.5.3 DESCRIPTION OF THE HOST INTERFACE REGISTERS

This section describes the operation of the register bits in the SAA7391 host interface block.

7.5.3.1 ADATA

This is a 12-byte FIFO used to transfer data from the microcontroller to the host. To transfer data the 'trant' bits (0 to 2) of the DTCTR register must be set to 101.

7.5.3.2 IFCTRL

Table 57 IFCTRL: address FF81H (note 1)

ACCESS	BIT 7	BIT 6	BIT 5	BIT 4	BIT 3	BIT 2	BIT 1	BIT 0
RW	cmdien	dteien	drqien	ultra_stopien	–	srstien	–	–

Note

- Bits 'cmdien', 'dteien', 'drqien' and 'ultra_stopien', are the enable bits for interrupt bits 'cmdi', 'dtei', 'drqi' and 'ultra_stop' in the IFSTAT register. These are interrupt masks, enabling/disabling the microcontroller interrupt pin. They do not affect the bits in the IFSTAT register. If set to logic 1, the corresponding interrupt is enabled. It should be noted that these masks do not clear the interrupts. Bit 2 (srstien) is asserted at power-on reset, enabling the 'srsti' interrupt. If set to logic 1 the 'srsti' interrupt is disabled.

7.5.3.3 DBCL and DBCH

These are the ATAPI byte count registers. DBCL is the lower byte (bits 7 to 0) register and DBCH is the higher byte (bits 15 to 8) register. These registers are read/writable for both the PC host and microcontroller.

Table 58 ATAPI byte count registers; addresses FF82H (DBCL) and FF83H (DBCH)

ACCESS	BIT 7	BIT 6	BIT 5	BIT 4	BIT 3	BIT 2	BIT 1	BIT 0
RW	Data Byte Count register bits (bits 7 to 0)							
RW	Data Byte Count register bits (bits 15 to 8)							

The data byte counter is used by the microcontroller to control the number of bytes that are transferred during a data transfer. During memory-to-host data transfers the data byte counter is decremented after every host read. During host-to-memory data transfers the data byte counter is decremented as data is written into the external buffer memory. The host may write to DBCL/DBCH to indicate to the microcontroller the maximum transfer/reception length, which may be updated by the auto sequencer PACKETSIZE STORE registers or from the TRANSFER COUNTER (for the remainder packet size) or directly by the microcontroller. The host can then read back the updated byte count to be transferred.

7.5.3.4 DTRG

Writing to this register starts a data transfer. The data written is discarded.

7.5.3.5 DTACK

Writing to this register clears the DTEI interrupt and the 'A0comp/crc_error' flag. The data written is discarded.

ATAPI CD-R block encoder/decoder

SAA7391

7.5.3.6 \overline{RESET}

Writing to this register resets the SAA7391 and initializes all the registers on the device.

Table 59 \overline{RESET} ; address FF86H (note 1)

ACCESS	BIT 7	BIT 6	BIT 5	BIT 4	BIT 3	BIT 2	BIT 1	BIT 0
W	reserved					hsel		

Note

- The 'hsel' bits (see Table 60) control the mode of operation of the host interface block. After a power-on reset the 'hsel' bits default to 000, i.e. the host 3-state pins are 3-stated. The firmware must configure the 'hsel' bits for the desired mode of operation after every hardware reset. It should be noted that any write operation by the microcontroller to this register will result in the resetting of all other SAA7391 registers to their default condition.

Table 60 Description of the 'hsel' bits

hsel2 to hsel0	HOST INTERFACE MODE	DESCRIPTION
000	unknown host	all host pins 3-state, default after hardware reset
001	ATAPI	ATAPI Interface mode
011	generic 8-bit	generic interface mode, with 8-bit transfers
100	generic 16-bit	generic interface mode, with 16-bit transfers
others	reserved	for future enhancements

7.5.3.7 *ASTAT*

This is the ATAPI status register.

Table 61 *ASTAT*: address FF87H (notes 1 and 2)

ACCESS	BIT 7	BIT 6	BIT 5	BIT 4	BIT 3	BIT 2	BIT 1	BIT 0
RW	bsy	drdy	dmar	dsc	drq	corr	reset	check

Notes

- The 'bsy' flag bit 7 will be set to logic 1 when:
 - The host writes to the ACMD register and the SAA7391 is the selected drive.
 - The host writes the execute drive diagnostic command (90H) to the ACMD register.
 - The host writes to the ADCTR register and sets the 'srst' bit.
 - There is a hardware reset.
- If a host interrupt is asserted then it will be cleared by writing to this register.

7.5.3.8 *ITRG*

In the ATAPI mode writing to this register generates a PC host interrupt on the INT pin. This interrupt is cleared when the PC host reads the ATAPI status register (*ASTAT*) or writes to the ATAPI command register.

7.5.3.9 *ADRADR*

This is the ATAPI drive address register for the SAA7391. This uses an obsolete register address ($\overline{CS1} \rightarrow DA0 = 10111$) from the ATAPI register map in the ATAPI specification. Bit 7 of this register is high-impedance when read by the host. After a reset the ATAPI registers are all cleared except for the *ASTAT* register which has its 'bsy' bit set.

ATAPI CD-R block encoder/decoder

SAA7391

7.5.3.10 ASAMT

This is the ATAPI SAM TAG byte register.

7.5.3.11 DTCTR

The DTCTR register controls data transfer flows in the host interface block. When reset this register is cleared to all zeros except for the 'rdrv' bit which is set to logic 1. This means the SAA7391 will be then set to device 1 (slave) after a reset.

There are several possible data transfers through the SAA7391 host interface block and these are selected using the 'trant' bits. The transfers are described in Table 64.

Table 62 DTCTR: address FF8BH (see Tables 63 and 64)

ACCESS	BIT 7	BIT 6	BIT 5	BIT 4	BIT 3	BIT 2	BIT 1	BIT 0
RW	reserved	dmamode	dma	ultra_dma	rdrv	trant		

Table 63 Description of the DTCTR register bits

BIT	NAME	DESCRIPTION
6	dmamode	DMA mode select; controls whether the DMA transfer is single word or multi-word dmamode = 1; host Interface DMA data transfers are multi-word dmamode = 0; host Interface DMA data transfers single word
5	dma	this bit is used to configure the SAA7391 hardware for either a DMA type transfer or a PIO type transfer dma = 1; configures the SAA7391 for a DMA transfer dma = 0; configures the SAA7391 for a PIO type transfer
4	ultra_dma	this bit configures the SAA7391 for ultra DMA transfers; the SAA7391 must also be configured for multi-word DMA transfers for correct operation of ultra DMA i.e. bits 5 and 6 of the DTCTR register must also be set to logic 1 to select ultra DMA ultra_dma = 1; configure the SAA7391 for ultra DMA (must be select dma = 1 and dmamode = 1) ultra_dma = 0; default for non-ultra DMA transfers
3	rdrv	this bit selects the device number: the polarity of this bit must be the same as the 'drv' bit in the ATAPI drive select register (ADRSEL) in order for the SAA7391 to communicate with the PC host interface; after reset the microcontroller should configure the 'rdrv' bit as no default may be assumed. rdrv = 1; the SAA7391 is device 1 i.e slave rdrv = 0; the SAA7391 is device 0 i.e master

ATAPI CD-R block encoder/decoder

SAA7391

Table 64 Description of the 'trant' bits

trant (bits 2 to 0)	FROM	TO	MAXIMUM BYTES	NOTES
000	–	host	65535 (ATAPI, PIO)	maximum bytes for auto sequence DMA is 4.3 Gbytes
001	host	memory	65535 (ATAPI, PIO)	maximum bytes for auto sequence DMA is 4.3 Gbytes
010	microcontroller	memory	–	redundant
011	memory	microcontroller	–	redundant
100	host	microcontroller	12	PIO; DBC not used, always 12 bytes
101	microcontroller	host	12	DMA and PIO
11X	reserved	reserved	reserved	–

7.5.3.12 ADRSEL

This is the ATAPI drive select register.

Table 65 ADRSEL: address FF8CH

ACCESS	BIT 7	BIT 6	BIT 5	BIT 4	BIT 3	BIT 2	BIT 1	BIT 0
RW	1	1	1	drv ⁽¹⁾	–	–	–	–

Note

- Bit 4 of this register is the 'drv' bit. When this bit is the same as the 'rdrv' bit in the DTCTR register then the SAA7391 will be the selected ATAPI drive and will respond to commands and produce interrupts. The host interrupt pin will also be enabled when the SAA7391 is the selected drive.

7.5.3.13 AINTR

This is the ATAPI interrupt reason register. See the ATAPI specification for a detailed description of these register bits.

Table 66 AINTR: address FF8DH

ACCESS	BIT 7	BIT 6	BIT 5	BIT 4	BIT 3	BIT 2	BIT 1	BIT 0
RW	–	–	–	–	–	release	io	cod

7.5.3.14 AERR

This is the ATAPI error register. See the ATAPI specification for a detailed description of these register bits.

Table 67 AERR: address FF8EH

ACCESS	BIT 7	BIT 6	BIT 5	BIT 4	BIT 3	BIT 2	BIT 1	BIT 0
RW	sense key				mcr	abrt	eom	–

ATAPI CD-R block encoder/decoder

SAA7391

7.5.3.15 ACMD

This is the ATAPI command register. This register is read-only to the microcontroller and write-only to the host. The host should only write to this register when the 'bsy' and 'drq' flags are both zero (see ASTAT register; Section 7.5.3.7).

A 'cmdi' interrupt is generated when:

- The host writes to this register while the SAA7391 is the selected drive (the 'drv' bit in register ADRSEL is equal to the 'rdrv' bit in register DTCTR)
- The host writes the execute drive diagnostic command (90H) to this register.

The microcontroller interrupt (cmdi) is cleared by the SAA7391 when the ACMD register is read by the microcontroller.

7.5.3.16 ADCTR

This is the ATAPI device control register.

Table 68 ADCTR: address FF90H

ACCESS	BIT 7	BIT 6	BIT 5	BIT 4	BIT 3	BIT 2	BIT 1	BIT 0
R	reserved				1	srst ⁽¹⁾	nien ⁽²⁾	0

Notes

1. Setting the 'srst' bit causes a 'srsti' interrupt and the 'bsy' bit to be set.
2. Bit 'nien' is used to enable or disable the host interrupt. When 'nien' is logic 0 and the drive is selected then the host interrupt pin will be enabled. If 'nien' is logic 1 or the drive is not selected then the host interrupt pin will be in a high-impedance state.

7.5.3.17 AFEAT

This is the ATAPI features register. See the ATAPI specification for a detailed description of these register bits.

Table 69 AFEAT: address FF91H

ACCESS	BIT 7	BIT 6	BIT 5	BIT 4	BIT 3	BIT 2	BIT 1	BIT 0
R	–	–	–	–	–	–	overlap	dma

7.5.3.18 IFSTAT

Table 70 IFSTAT: address FF92H (note 1); see Table 71

ACCESS	BIT 7	BIT 6	BIT 5	BIT 4	BIT 3 ⁽²⁾	BIT 2	BIT 1 ⁽²⁾	BIT 0 ⁽²⁾
RW	$\overline{\text{cmdi}}$	$\overline{\text{dtei}}$	$\overline{\text{drqi}}$	$\overline{\text{ultra_stop}}$	$\overline{\text{dtbsy}}$	$\overline{\text{srsti}}$	$\overline{\text{reset08}}$	$\overline{\text{a0comp/}}/\overline{\text{crc_error}}$

Notes

1. All interrupts may be negated by writing a logic 1 to their associated IFSTAT locations.
2. These bits are flags which do not generate interrupts.

ATAPI CD-R block encoder/decoder

SAA7391

Table 71 Description of the IFSTAT register bits

BIT	NAME	DESCRIPTION
7	$\overline{\text{cmdi}}$	Command interrupt: in the ATAPI mode this bit is asserted when the PC host has written to the ATAPI command register (see ACMD register; Section 7.5.3.15) and the drive is selected. It is also asserted when the host writes the execute drive diagnostic command (90H) to the ATAPI command register, regardless of whether the drive is selected. It is negated when the microcontroller reads the ACMD register or writes logic 1 to ' $\overline{\text{cmdi}}$ '.
6	$\overline{\text{dtei}}$	Data transfer end interrupt: this bit is asserted at the end of data transfer. It is negated when the microcontroller writes to the DTACK register or writes logic 1 to ' $\overline{\text{dtei}}$ '. If the ATAPI mode is selected this bit is also asserted when a packet command has been received and after a microcontroller memory transfer. The interrupt generated by this bit can be masked by the auto sequencer.
5	$\overline{\text{drqi}}$	Auto sequencer data request interrupt: if enabled by ' $\overline{\text{drqien}}$ ' (IFCTRL; see Table 57), this bit is asserted after every load of the packet size store into DBCH/DBCL during an ' $\overline{\text{autodr}}$ ' DMA sequence. ' $\overline{\text{drqi}}$ ' is cleared along with its associated interrupt by the microcontroller writing logic 1 to ' $\overline{\text{drqi}}$ '.
4	$\overline{\text{ultra_stop}}$	Ultra ATA stop before end of transfer interrupt: if enabled by ' $\overline{\text{ultra_stopien}}$ ' (IFCTRL; see Table 57), this bit is asserted if the host stops an ultra ATA data transfer before the TRANSFER COUNTER has reached zero, when ' $\overline{\text{autodr}}$ ' is selected, or before the DBCH/DBCL task file registers reach zero when ' $\overline{\text{autodr}}$ ' is not selected. ' $\overline{\text{ultra_stop}}$ ' is cleared along with its associated interrupt by the microcontroller writing logic 1 to ' $\overline{\text{ultra_stop}}$ ' (IFSTAT; see Table 70).
3	$\overline{\text{dtbsy}}$	Data transfer busy: this bit indicates if a data transfer is taking place. It is asserted by writing to the DTRG register and is negated at the end of the transfer.
2	$\overline{\text{srsti}}$	Interrupt/status transfer busy: in ATAPI mode this bit is asserted when the host writes to the ATAPI device control register and sets the ' $\overline{\text{srsti}}$ ' bit. It is negated when the microcontroller reads the ADCTR register or by writing a logic 1 to the ' $\overline{\text{srst}}$ ' (ADCTR; see Table 68). It should be noted that if this bit is asserted in the ATAPI mode then the microcontroller interrupt will also be asserted. The ' $\overline{\text{srsti}}$ ' interrupt cannot be disabled.
1	$\overline{\text{reset08}}$	The reset command 08 has been received: this bit indicates that the last command received was the 08 reset command. Reading the command register ACMD will negate this bit and its associated interrupt.
0	$\overline{\text{a0comp/crc_error}}$	The A0 command auto sequence is completed or ultra ATA CRC error flag: this bit indicates that A0 command auto sequence is completed i.e. the correct A0 command has been read and the host interface has been configured to receive the 12 byte packet. This bit does generate an interrupt but should be used in conjunction with the ' $\overline{\text{dtei}}$ ' interrupt. A microcontroller write to DTACK will negate the ' $\overline{\text{a0comp}}$ ' bit. After an ultra DMA data transfer (read from the SAA7391 or write to the SAA7391) this bit may be used in conjunction with the DTEI interrupt to indicate data integrity. If the ' $\overline{\text{crc_error}}$ ' bit = 0 then the last data transfer was corrupt. Again writing to DTACK will negate this bit.

7.5.3.19 APCMD

During the ATAPI mode this register is used to read the packet command sent by the host. The packet command can only be received if the appropriate mode has been selected (see DTCTR register; Table 62) and a data transfer has been started (see DTRG register; see Table 56).

ATAPI CD-R block encoder/decoder

SAA7391

7.5.3.20 HICONF0

This is the host interface configuration register 0

Table 72 HICONF0: address FF94H

ACCESS	BIT 7	BIT 6	BIT 5	BIT 4	BIT 3	BIT 2	BIT 1	BIT 0
RW	ultractrl2 to ultractrl0			dynhosthiprior		hrequest		shadow

Table 73 Description of the HICONF0 register bits

BIT	NAME	DESCRIPTION
7 to 5	ultractrl2 to ultractrl0	ultra control bits (3 to 1), see Section 7.5.3.22
4	dynhosthiprior	dynhosthiprior (1) 0 = N = Dynamic Host High Priority asserted when FIFO is $\frac{1}{3}$ full 1 = N = Dynamic Host High Priority asserted when FIFO is $\frac{1}{2}$ full
3	dynhosthiprior	dynhosthiprior (0) 0 = (default) dynamic host high priority off 1 = dynamic host high priority on when FIFO bytes, N, off when > N
2 and 1	hrequest	hrequest = 00; (default) assert host request when FIFO $\frac{2}{3}$ full hrequest = 01; assert host request when FIFO $\frac{1}{2}$ full hrequest = 10; assert host request when FIFO $\frac{1}{3}$ full hrequest = 11; assert host request when FIFO (full – 2 bytes)
0	shadow	shadow enable: this bit controls whether shadowing of single drive configurations is enabled shadow = 1; enables shadowing for single drive configurations when the SAA7391 is master and slave is non existent shadow = 0; disables shadowing

7.5.3.21 HICONF1

This is the host interface configuration register 1.

Table 74 HICONF1: address FF95H (see Table 75)

ACCESS	BIT 7	BIT 6	BIT 5	BIT 4	BIT 3	BIT 2	BIT 1	BIT 0
RW	dmaen	shhpbit	udmaoff	flushfifo	–	unmaskdtei	clear_reg	ultractrl3

ATAPI CD-R block encoder/decoder

SAA7391

Table 75 Description of the HICONF1 register bits

BIT	NAME	DESCRIPTION
7	dmaen	DMA suspend: this bit controls whether DMA transfers in generic mode are suspended dmaen = 1; host Interface DMA data transfers in generic can be temporarily interrupted dmaen = 0; host Interface DMA data transfers in generic mode cannot be suspended
6	shhpbit	this bit allows statistical host high priority to be turned off shhpbit = 0; (default) statistical host high priority turned on shhpbit = 1; statistical host high priority turned off
5	udmaoff	this bit allows 'udma' to be turned off at the end of a transfer udmaoff = 0; (default) switch off the 'ultra_ata' bit in the DTCTR register udmaoff = 1; do nothing
4	flushfifo	Flush 12-byte command FIFO: writing a logic 1 to this bit will 'flush' clear the command FIFO pointer to zero. Clearing the pointer is required if a spurious command is received while the FIFO is being loaded and is also used to ensure a 12-byte command read by the auto sequencer. flushfifo = 1; writing a logic 1 clears the FIFO pointer to zero flushfifo = 0; do nothing
2	unmaskdtei	Unmask data transfer end interrupt during 'autodrq' sequence: this bit will disable the auto sequencer masking of the 'dtei' interrupts during the 'autodrq' sequence. The 'dtei', bit 6 of the IFSTAT register is not effected by 'unmaskdtei'. If 'unmaskdtei' is asserted the sequencer on detecting the next 'dtei' interrupt, will set the 'bsy' flag, negate the 'drq' flag and suspend operation. The microcontroller may then reconfigure the host interface before negating unmaskdtei bit. When 'unmaskdtei' is negated the sequencer will negate the 'dtei' interrupt and operate as normal. unmaskdtei = 1; disable 'autodrq' sequencer masking of 'dtei' interrupts and suspend the sequence operation on next 'dtei' interrupt unmaskdtei = 0; no effect, or restart 'autodrq' sequencer operation
1	clear_reg	Clear auto sequencer transfer counter and packet size store to zero: this bit will clear the transfer counter and packet size store to zero if a logic 1 is written to it. After the write operation the registers operate as normal and the 'clear_reg' bit will have no effect unless written to again. clear_reg = 1; clears to zero transfer counter and packet size store clear_reg = 0; no effect
0	ultractrl3	ultra control bit 3; see Section 7.5.3.22

ATAPI CD-R block encoder/decoder

SAA7391

7.5.3.22 Description of the ultra control bits

The 'ultractrl' register bits can be used to add system clock cycles to various timing limits used in the host interface ultra DMA transfer engine.

This enables the SAA7391 to meet ultra DMA Mode 0 timings when the SAA7391 system clock is higher than 33.8688 MHz.

When the SAA7391 system clock is 33.8688 MHz, maximum data transfer rates in ultra DMA Mode 0 are achieved by setting 'ultractrl' to (0001).

For information on meeting Mode 0 timings for system clocks other than 33.8688 MHz, please consult the user manual or product support.

7.5.3.23 HISEQ

Table 76 HISEQ: host interface sequencer register; address FF96H (see Table 77)

ACCESS	BIT 7	BIT 6	BIT 5	BIT 4	BIT 3	BIT 2	BIT 1	BIT 0
RW	autoa0	autodrq	comp	error	sus_seq	repeat autoa0	–	–

Table 77 Description of the HISEQ register bits

BIT	NAME	DESCRIPTION
7	autoa0	automatic A0 packet transfer enable: this bit enables the sequencer to automatically handle transfer of A0 packet bytes autoa0 = 1; enables automatic transfer of A0 packet bytes autoa0 = 0; disables automatic transfer of A0 packet bytes
6	autodrq	enables the auto data request sequence: this bit enables automatic handling of data requests in PIO and DMA mode transfers autodrq = 1; auto sequencer is enabled to perform auto data requests autodrq = 0; auto sequencer is not enabled to perform auto data request
5	comp	Completion sequence for 'autodrq': this bit indicates that the auto completion sequence should be performed after the last data transfer. This bit is only valid when the auto sequencer is enabled. comp = 1; enable the auto sequencer to automate the completion sequence comp = 0; disable the auto completion sequence
4	error	completion sequence with error status: this bit is copied to the check bit of the ASTAT register just before an auto completion sequence is performed error = 1; completion sequence with error status in check bit of ASTAT error = 0; completion without error status
3	sus_seq	Suspend auto sequence: this bit suspends the auto sequencer for debug. If the suspend state is a write to register state then the write operation will only take place when after the 'sus_seq' bit is negated. sus_seq = 1; suspend sequencer in present state sus_seq = 0; normal sequence operation
2	repeat autoa0	Repeat the A0 packet reception auto sequence after an 'autodrq' or auto completion sequence. This bit, if set before an 'autodrq' or auto completion sequence, will be copied to 'autoa0' bit when the sequencer is reset at the end of an 'autodrq' or auto completion sequence. This bit is negated at the end of the 'autoA0' sequence. Its effect is to repeat the 'autoA0' sequence one more time only. It should be noted that this bit is only available on RODAP and not the M1 data base. repeat autoa0 = 1; repeat 'autoA0' sequencer after 'autodrq' or auto completion repeat autoa0 = 0; no effect

ATAPI CD-R block encoder/decoder

SAA7391

7.5.3.24 SHSTAT

Table 78 SHSTAT: shadow status register; address FF97H

ACCESS	BIT 7	BIT 6	BIT 5	BIT 4	BIT 3	BIT 2	BIT 1	BIT 0
W	0	0	0	0	0	0	0	shcheck ⁽¹⁾

Note

- Shadow check bit: 'shcheck' is the ATAPI CHECK bit in the slave shadow status register for the non-existent drive.
 - 1 = Indicates an error has occurred.
 - 0 = Indicates no error has occurred.

7.5.3.25 SHERR

Table 79 SHERR: shadow error register; address FF98H

ACCESS	BIT 7	BIT 6	BIT 5	BIT 4	BIT 3	BIT 2	BIT 1	BIT 0
W	0	0	0	0	0	shabrt ⁽¹⁾	0	0

Note

- Shadow abort bit: 'shabrt' is the ATAPI 'abrt' bit in the slave shadow error register for the non-existent drive. This bit will be read by the host in shadow mode only.
 - 1 = indicates requested command has been aborted.
 - 0 = indicates requested command successful.

7.5.3.26 HIDEV

Table 80 HIDEV: host interface device register; address FF99H (see Table 81)

ACCESS	BIT 7	BIT 6	BIT 5	BIT 4	BIT 3	BIT 2	BIT 1	BIT 0
RW	pdiag out	pdiag enable	dasp out	dasp enable	pdiag in	dasp in	–	hosthipi

ATAPI CD-R block encoder/decoder

SAA7391

Table 81 Description of the HIDEV register bits

BIT	NAME	DESCRIPTION
7	pdiag out	this bit is the passed diagnostics signal output from the SAA7391 pdiag out = 1; writing logic 1 to this bit drives the $\overline{\text{PDIAG}}$ pin HIGH if the pad enable ('pdiag enable' bit 6) is set to logic 1. It is recommended that this bit is written LOW and that the enable bit is driven to emulate an open-collector output. pdiag out = 0; writing logic 0 to this bit sets the $\overline{\text{PDIAG}}$ pin LOW if the pad enable ('pdiag enable' bit 6) is set to logic 1
6	pdiag pad enable	this bit default is an input to the SAA7391 pdiag pad enable = 1; writing logic 1 to this bit enables the $\overline{\text{PDIAG}}$ driver output of the SAA7391 pdiag pad enable = 0; default on power-up allowing external control of the 'pdiag in' bit 3
5	dasp out	This bit is the device active slave present signal output. This pin is open-collector with an external pull-up resistor. The $\overline{\text{DASP}}$ bit must be set to logic 1 in order to determine if any other device is driving this signal. dasp out = 1; writing logic 1 to this bit drives $\overline{\text{DASP}}$ HIGH if the pad enable ('dasp enable' bit 4) is set to logic 1. It is recommended that this bit is written LOW and that the enable bit is driven to emulate an open-collector output. dasp out = 0; writing logic 0 to this bit sets the $\overline{\text{DASP}}$ pin LOW if the pad enable (dasp enable bit 4) is set to logic 1
4	dasp pad enable	this bit default is an input to the SAA7391 dasp pad enable = 1; writing logic 1 to this bit enables the $\overline{\text{DASP}}$ driver output of the SAA7391 dasp pad enable = 0; default on power-up allowing external control of the dasp in bit 2
3	pdiag in	this bit is the passed diagnostics signal input to the SAA7391, only valid if 'pdiag enable' bit 6 is set to logic 0 (default = 0)
2	dasp in	this bit is the device active slave present signal input to the SAA7391, only valid if 'dasp enable' bit 4 is set to logic 0 (default = 0)
0	hosthipi	This bit allows the host interface to increase its priority rating when requesting a data transfer between itself and the SAA7391 memory processor. With host high priority set the host data transfer requests are given the second highest priority, the highest given to the microcontroller. hosthipi = 1; writing logic 1 increase host interface priority above all other data transfer requests, bar the microcontroller. hosthipi = 0; writing logic 0 to this bit (default setting) gives low priority to the host interface data transfer request.

ATAPI CD-R block encoder/decoder

SAA7391

7.5.4 TRANSFER COUNTER

The transfer counter register defines the total transfer length to be transferred to or from the host. This register is loaded by the microcontroller and decrements synchronously with the DBCH/DBCL registers. The remainder packet size can be loaded from the transfer counter into DBCH or DBCL when the transfer counter value becomes less than the packet size store.

Table 82 Transfer counter register

ADDRESS	ACCESS	BIT 7	BIT 6	BIT 5	BIT 4	BIT 3	BIT 2	BIT 1	BIT 0
FFA0H	RW	byte count (bits 7 to 0)							
FFA1H	RW	byte count (bits 15 to 8)							
FFA2H	RW	byte count (bits 23 to 16)							
FFA3H	RW	byte count (bits 31 to 24)							

7.5.5 PACKET SIZE STORE

The packet size store will be loaded from the DBCH or DBCL registers when the host writes to ACMD, provided the drive is selected. It may also be updated by the microcontroller. The DBCH/DBCL registers will be auto loaded from the packet size store on condition that the transfer counter contains an equal or greater value than that held in the packet size store.

Table 83 Packet size store

ADDRESS	ACCESS	BIT 7	BIT 6	BIT 5	BIT 4	BIT 3	BIT 2	BIT 1	BIT 0
FFA4H	RW	byte count (bits 7 to 0)							
FFA5H	RW	byte count (bits 15 to 8)							

7.5.6 SEQUENCER STATUS

7.5.6.1 *Sequencer status*

For debugging the auto sequencer a sequencer status register has been provided (address FF6AH). A suspend sequence bit has been provided ('hiseq' bit 4; see Table 76), which if asserted (logic 1) will suspend the auto sequencer operation at its present state. The suspended state may then be read from the sequencer state register. If the sequencer state is a write to a host interface registers state, then the sequencer will perform the write operation after the suspend sequencer bit is negated by the microcontroller.

Table 84 Sequencer status: address FFA6H (note 1)

ACCESS	BIT 7	BIT 6	BIT 5	BIT 4	BIT 3	BIT 2	BIT 1	BIT 0
R	–	–	sequencer state (bits 5 to 0)					

Note

1. For an explanation of the sequence state number see the user guide. The user guide is available from product support.

ATAPI CD-R block encoder/decoder

SAA7391

7.5.6.2 Auxiliary block memory processor registers

The registers given in Table 85 are located in the Aux block of the and control the SAA7391 memory processor buffer management. Transfer to/from the host is possible as soon as the HOSTBYTECOUNT is non-zero, and the HOSTCURSEGCNT is non-zero.

The 'chan0' and 'chan1' bits control the sequencing of sub-block transfers. They indicate the number of offset/length pairs to use for each block being transferred. Normally only channels 0 and 1 are needed for Mode 2 host transfers. Channels 2 and 3 are available for special READ-CD command options.

An interrupt is associated with HOSTBYTECOUNT becoming zero. This is an indication to the microcontroller to reload the HOSTCURSEG and HOSTBYTECOUNT registers for the next transfer.

The HOSTCURSEG, HOSTBYTEOFFSET and HOSTBYTECOUNT registers indicate the address of the next byte to be transferred to or from the host, in order that the status of the interface may be read. The operation of the HOSTBYTECOUNT and HOSTBYTEOFFSET registers is given in Table 85.

Table 85 Host interface DMA pointers

ADDR	ACCESS	NAME	BIT 7	BIT 6	BIT 5	BIT 4	BIT 3	BIT 2	BIT 1	BIT 0
FF45H	RW	HOSTCURSEG-L	s7	s6	s5	s4	s3	s2	s1	s0
FF44H	RW	HOSTCURSEG-H	chan1	chan0	–	s12	s11	s10	s9	s8
FF66H	RW	HOSTCURSEGCNT	b7	b6	b5	b4	b3	b2	b1	b0
FF59H	RW	HOSTSUBBLKOFFSET0-L	a7	a6	a5	a4	a3	a2	a1	a0
FF58H	RW	HOSTSUBBLKOFFSET0-H	autoform	form	–	–	a11	a10	a9	a8
FF5DH	RW	HOSTSUBBLKOFFSET1-L	a7	a6	a5	a4	a3	a2	a1	a0
FF5CH	RW	HOSTSUBBLKOFFSET1-H	autoform	form	–	–	a11	a10	a9	a8
FF51H	RW	HOSTSUBBLKOFFSET2-L	a7	a6	a5	a4	a3	a2	a1	a0
FF50H	RW	HOSTSUBBLKOFFSET2-H	autoform	form	–	–	a11	a10	a9	a8
FF55H	RW	HOSTNEXTSEG-L	a7	a6	a5	a4	a3	a2	a1	a0
FF54H	RW	HOSTNEXTSEG-H	autoform	form	–	a12	a11	a10	a9	a8
FF5BH	RW	HOSTSUBBLKCOUNT0-L	c7	c6	c5	c4	c3	c2	c1	c0
FF5AH	RW	HOSTSUBBLKCOUNT0-H	–	–	–	–	c11	c10	c9	c8
FF5FH	RW	HOSTSUBBLKCOUNT1-L	c7	c6	c5	c4	c3	c2	c1	c0
FF5EH	RW	HOSTSUBBLKCOUNT1-H	–	–	–	–	c11	c10	c9	c8
FF53H	RW	HOSTSUBBLKCOUNT2-L	c7	c6	c5	c4	c3	c2	c1	c0
FF52H	RW	HOSTSUBBLKCOUNT2-H	–	–	–	–	c11	c10	c9	c8
FF57H	RW	HOSTNEXTSEGCOUNT	c7	c6	c5	c4	c3	c2	c1	c0
FF56H	RW	HOSTRELOADFLAGS	rel1	rel2	–	–	c11	c10	c9	c8
FF43H	RW	HOSTBYTEOFFSET-L	a7	a6	a5	a4	a3	a2	a1	a0
FF42H	RW	HOSTBYTEOFFSET-H	autoform	form	–	–	a11	a10	a9	a8
FF65H	RW	HOSTBYTECOUNT-L	c7	c6	c5	c4	c3	c2	c1	c0
FF64H	RW	HOSTBYTECOUNT-H	–	–	–	–	c11	c10	c9	c8
FF69H	RW	HOSTRELSEG-L	s7	s6	s5	s4	s3	s2	s1	s0
FF68H	RW	HOSTRELSEG-H	chan1	chan0	–	s12	s11	s10	s9	s8
FF6BH	RW	AUX_FORM_SCAN	c7	c6	c5	c4	c3	c2	c1	c0

ATAPI CD-R block encoder/decoder

SAA7391

Table 86 Decoding 'chan' bits

VALUE	DESCRIPTION
00	use extent 0
01	use extent 0 to 1
10	use extent 0 to 2
11	use extent 0 to 3 (see also Section 7.5.8)

7.5.7 HOST INTERFACE DMA SPECIAL BITS

Table 87 Decoding bits 7 and 6 of HOSTSUBBLKOFFSETX-H (note 1)

BIT	NAME	VALUE	DESCRIPTION
7	autoform	0	unconditional transfer
		1	only transfer if previous Form bit matches bit 6
6	form	0	match last Form bit = 0, perform this transfer if success else reload host registers
		1	match last Form bit = 1, perform this transfer if success else reload host registers

Note

1. The last Form bit is the LSB of the byte that is situated at offset 12 in the current segment pointed at by HOSTCURSEG. This is the stored Form byte in the header.

7.5.8 AUTOMATIC BLOCK POINTER RELOAD PROGRAMMING

If either bit 6 or bit 7 are set in the HOSTRELOADFLAGS register, then when the HOSTRELOADCOUNT register becomes zero, the value of HOSTCURSEGCNT will be copied from HOSTNEXTSEGCOUNT and HOSTRELSEGMENT will be copied from HOSTNEXTSEG.

This causes the host transfer process to continue looping over the same region of memory in emulation of the Chaucer and Sequoia devices.

At the same time one of the bits HOSTRELOADFLAGS (bits 7 and 6) is reset on reload of the registers. The other bit retains its value. Therefore:

- Single auto-reload is allowed: HOSTRELOADFLAGS (bits 7 and 6) = 1 0
- No auto-reload: HOSTRELOADFLAGS (bits 7 and 6) = 0 0; pointer can be used as sub-block extent 3
- Multiple auto-reload: HOSTRELOADFLAGS (bits 7 and 6) = 0 1.

7.5.9 DMA TRANSFER PROGRAMMING OF THE HOST INTERFACE

The host interface is optimized for the normal read commands, handling all data transfers or contiguous data plus header requests automatically, with auto Form detection in Mode 2.

If discontinuous data which requires more than 3 sub-block extents e.g. for READ-CD is required then it is necessary to program the HOSTCURSEG, HOSTBYTECOUNT and HOSTBYTEOFFSET for each discontinuous part of each block that is to be transferred. Writing the value 1 into the 'hostblock' will cause the transfer to take place.

ATAPI CD-R block encoder/decoder

SAA7391

7.5.10 GENERIC INTERFACE OPERATION

Implementation of the generic interface with the NCR 53CF92 in a multiplexed bus configuration is shown in Fig.4. The host interface, after power-up, needs to be configured for the SCSI controller by writing the value 3 to the $\overline{\text{RESET}}$ register (address FF86H) for an 8-bit data transfer configuration and the value 4 for a 16-bit data transfer configuration. The NCR 53CF92 device is configured by tying its mode pin to ground. In this mode the NCR 53CF92 device expects from the microcontroller a multiplexed address/data bus. Multiplexed address/data bus is the only mode supported by the SAA7391.

The active LOW Chip Select (CS) signal from the SAA7391 is generated by the host interface. There are 32 specific SCSI addresses in the SAA7391 memory map, between location FFC0H and FFDFH. The CS pin will be active LOW for addresses in this range. The standard register set on the NCR 53CF92 contains 16 registers which are accessed when the CS is true. The specific register being accessed is determined by the states of the $\overline{\text{RD}}$ and $\overline{\text{WR}}$ signals together with the address pins A3 to A0.

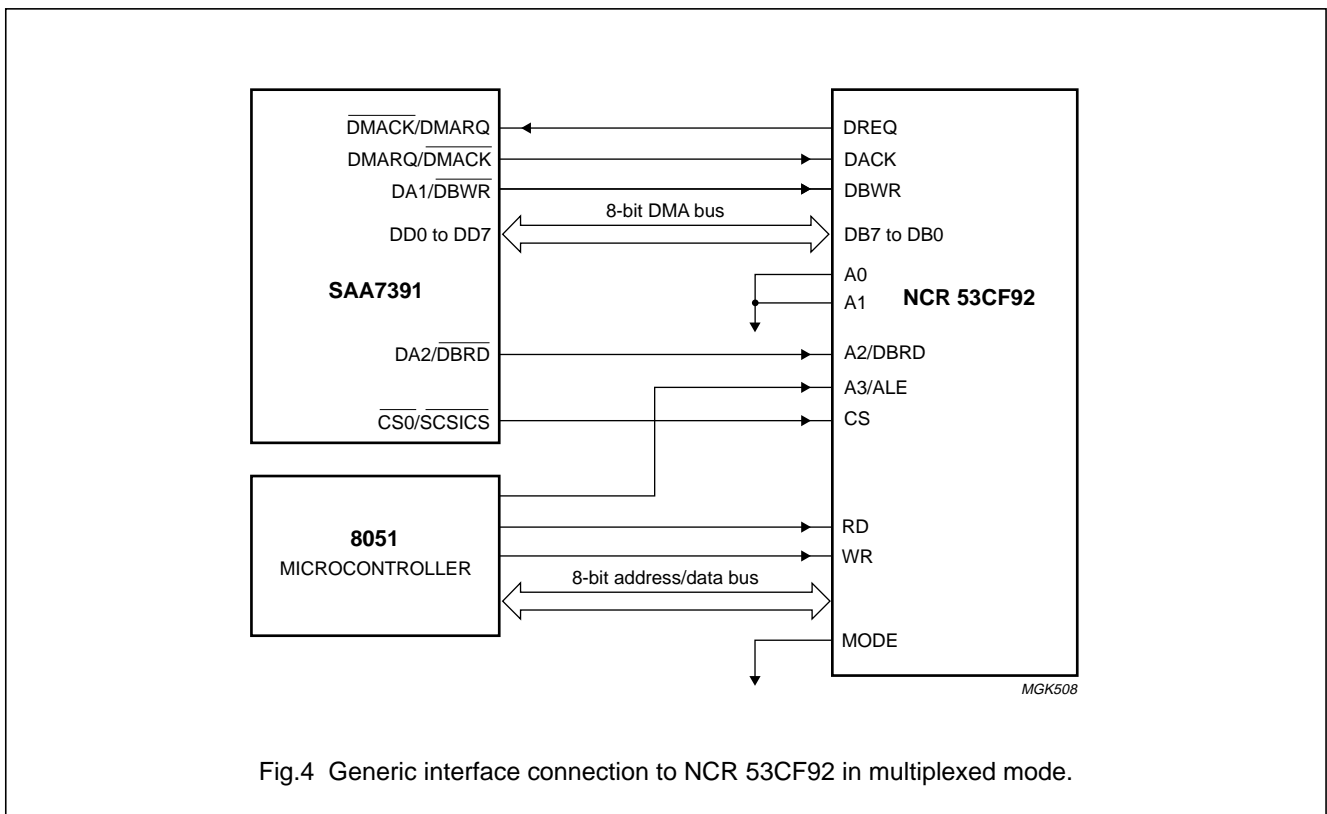

Fig.4 Generic interface connection to NCR 53CF92 in multiplexed mode.

ATAPI CD-R block encoder/decoder

SAA7391

7.5.11 DMA TRANSFERS IN GENERIC MODE

The host interface in generic mode will support two types of DMA transfer to the NCR device, namely:

- Normal DMA mode
- Burst DMA mode.

Both of these modes are 8 bit DMA transfers. During data transfers the microcontroller can suspend the DMA transfer (via HICONF1 register 'dmaen' bit 7) under the following conditions:

- An Interrupt received
- An abort received
- A register read required.

7.5.12 NORMAL DMA MODE

In this mode the host Interface transfers data in single bytes. This DMA mode is configured by setting 'dmamode' (DTCTR register bit 6) to zero, and DMA (DTCTR register bit 5) to one. Data flow direction and byte counts are configured the same as ATAPI DMA modes of data transfer, but with command information being received via the NCR SCSI controller registers external to the SAA7391 operation. The data transfer takes place as long as the DMA request signal DMARQ is true. The \overline{DMACK} signal is toggled by the host Interface for each byte transferred as shown in Fig.5.

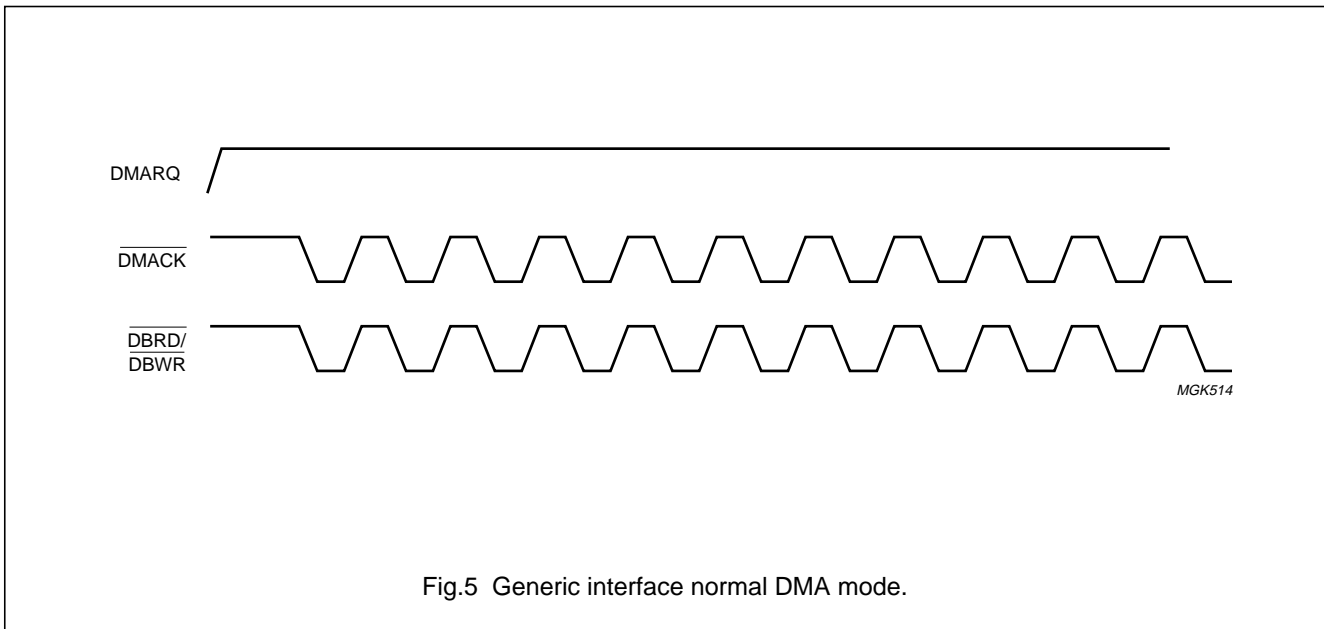

Fig.5 Generic interface normal DMA mode.

7.5.13 BURST DMA MODE USING MULTIPLEXED BUS CONFIGURATION

In this mode the DMA data is available on the DMA bus when both, \overline{DBRD} or \overline{DBWR} and \overline{DMACK} are true. \overline{DMACK} remains asserted throughout the transfer while \overline{DBRD} toggles for each transfer as shown in Fig.6. To configure the host interface the DMA mode and DMA bits (DTCTR bits 6 and 5) should be set to logic 1.

ATAPI CD-R block encoder/decoder

SAA7391

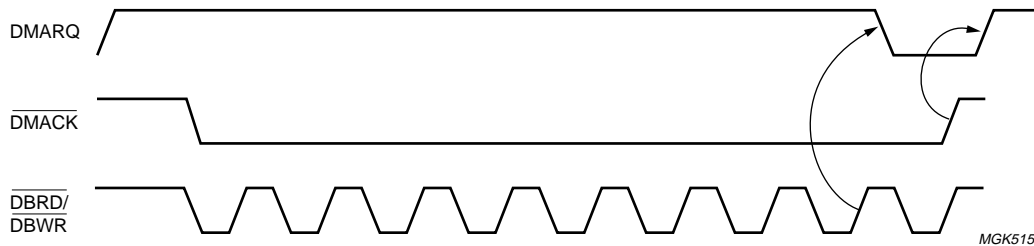

Fig.6 Burst DMA mode using multiplexed bus configuration.

7.6 Microcontroller interface

This section provides a brief introduction to the software and hardware environment expected in a system using the SAA7391 device. Because all of the SAA7391 registers are randomly accessible, the processor controlling the SAA7391 is able to use interrupts.

7.6.1 KERNEL BASED FIRMWARE

It is recommended that the sub-CPU runs a multi-tasking kernel to properly support the multiple 'threads' of operation that are required of it in use. Therefore the memory mapper specified in this document has the concept of having 2 pages of memory for data. Then one page of data space can be switched in to the memory map for each thread as needed, while still keeping a fixed part of the memory map for the interrupt service routines and other fixed housekeeping code and data.

7.6.2 16-BIT REGISTERS AUTOMATIC READ AND WRITE

All of the 16-bit registers provided in the SAA7391, are used by writing the Most Significant Bit (MSB) first. These registers are located in the address range FF20H to FF6FH together with some 8-bit registers. To facilitate 'snapshot' reading or writing of the 16-bit register an 8-bit holding register is provided to store the 'spare' byte of data.

This is implemented in such a way that a 16-bit read consists of a sample of the value of the register at the instant that the high byte was read from that register.

The low byte is kept in a holding register and presented to the sub-CPU when the low byte is requested. Even if the sub-CPU is interrupted (and the holding register is then stacked and replaced during the service routine) the 16-bit read will be the value of the register at a single instance in time.

Similarly for writing, the high byte is held in the holding register to be written later to the 16-bit register at the same time as the low byte is written to the SAA7391. Again the holding register must be saved during an Interrupt Service Routine (ISR) if the ISR itself is likely to cause any 16-bit reads or writes to take place. It should be noted that any ISR, which requires access to a 16-bit or 8-bit register in the address range FF20H to FF6FH, will overwrite the holding register and therefore its contents must be stacked before the interrupt is serviced. Furthermore, there is only one holding register that may be accessed both for reading and writing. In this way the interrupt routine can easily save data that was stored in the holding register before it was written.

A single location (TEMP_DATA, register FF6FH) is used as the location to read the value of the holding register, regardless of which address was used in the original read or write process. The IRS stacking process of the holding register is illustrated in Fig.8.

ATAPI CD-R block encoder/decoder

SAA7391

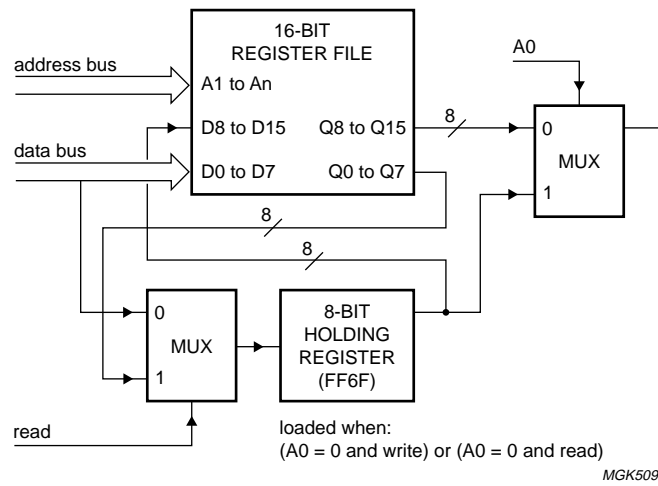

This is intended for big-endian high byte then low byte accesses to 16-bit register space.

Fig.7 Holding register used in 16-bit access via 8-bit bus.

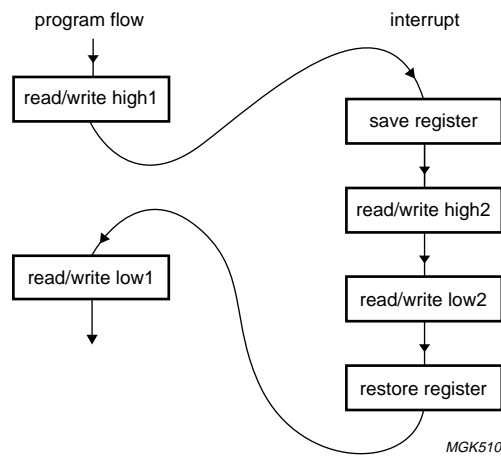

Fig.8 Stacking 8-bit holding register during interrupt service.

ATAPI CD-R block encoder/decoder

SAA7391

7.7 8051 CPU and memory management functions

The 8051 CPU and memory management functions are as follows:

- Device registers are memory mapped for faster direct access to the chip
- Provides direct access from sub-CPU to buffer RAM to support scratchpad accesses; this eliminates the need for extra RAM chips in the system
- Address space reserved for generic host interface control and status pass-through (it is shared with ATAPI register space; see Section 7.5)
- Interfaces to 8051 multiplexed address and data bus
- Two dynamically controllable RAM access modes allow trade-off between accessible scratchpad RAM size and RAM access time.

7.7.1 SUB-CPU BUS ACCESS TIMING

The fast and slow RAM access timing diagrams are illustrated in Figs 10 and 9. It should be noted that fast RAM access is not recommended due to its negative effect on the RAM bandwidth and the overall system performance.

In the fast RAM access mode all external accesses below C000 are expected to be program fetches. A DRAM access cycle is not begun. Above C000, the RAM cycle begins on the falling edge of ALE hence the number of 8051 wait states can be reduced. This is not however recommended.

The disadvantage is, that the RAM access cycle is started regardless of whether it will be needed. This has the effect of aborting any other on-going use of the buffer memory and reducing the available bandwidth.

Consequently, the number of wait states on accessing RAM must be greater. In return, more RAM is accessible.

In the slow RAM access mode the RAM access cycle starts on the falling edge of RD or WR, if PSEN is HIGH, this being the first time in the 8051 external memory access cycle that it is possible to determine that an XDATA access is in fact being made.

This access mode has a lower impact on the buffer RAM memory bandwidth as only accesses that are needed are made. The two modes are under control of a register bit, and it is possible to switch between them at any time.

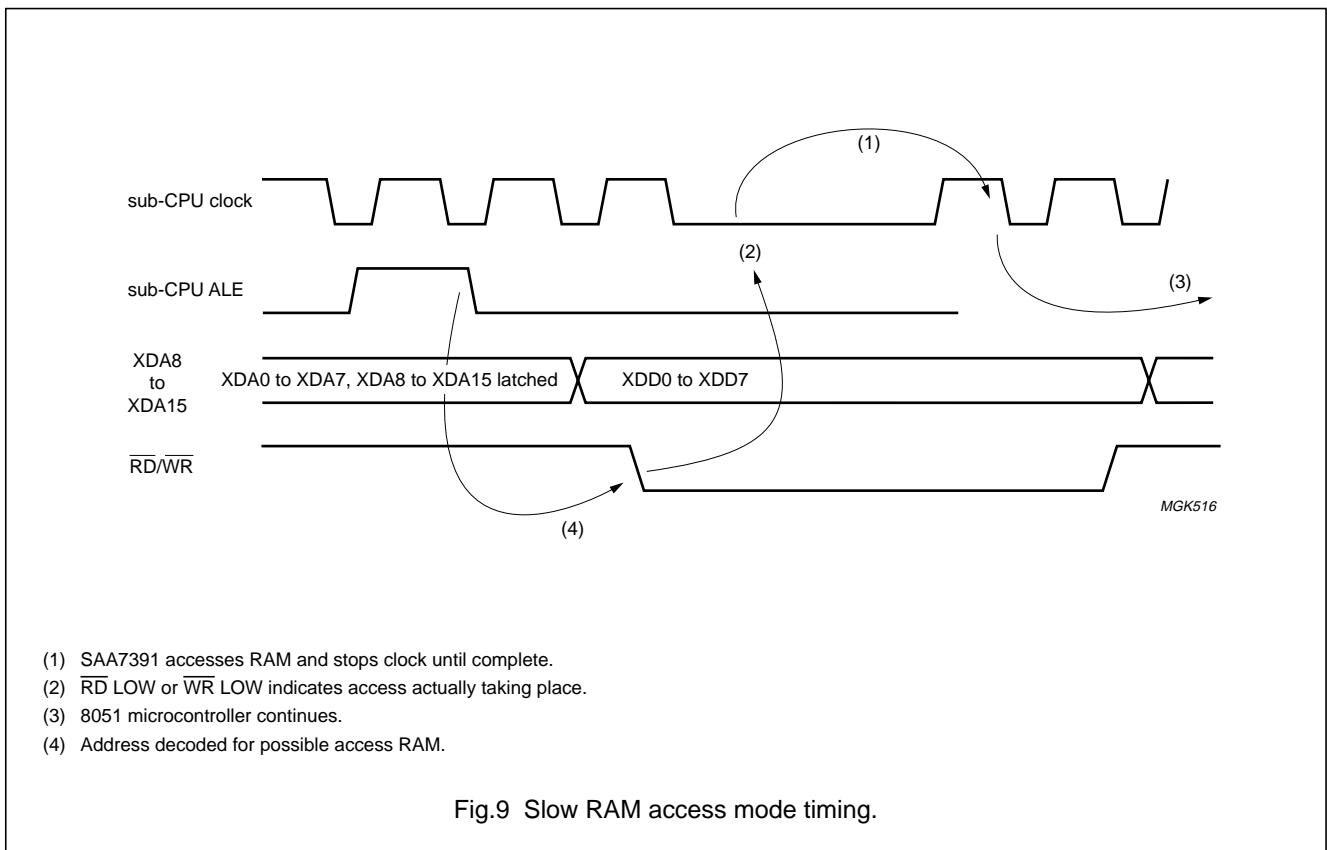

ATAPI CD-R block encoder/decoder

SAA7391

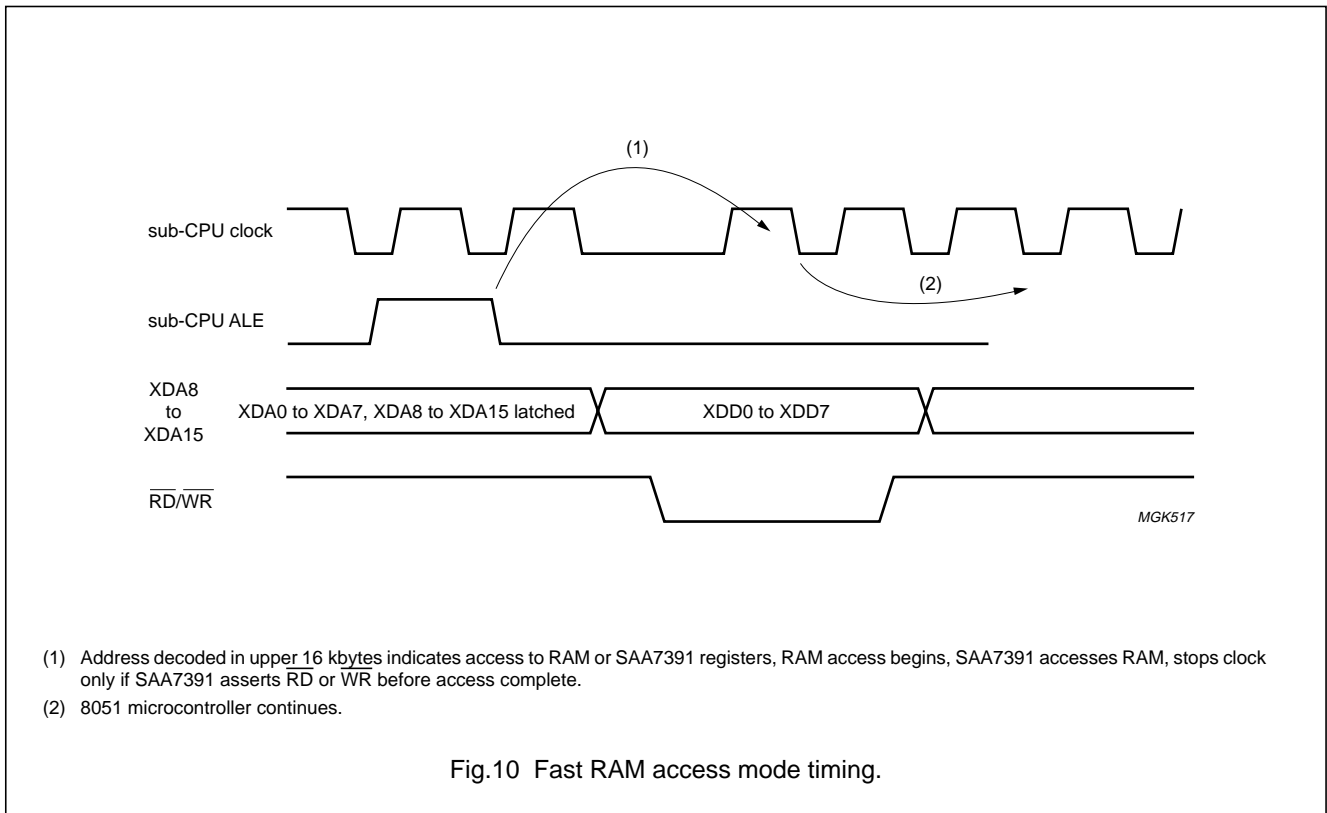

7.7.2 BUFFER MEMORY ORGANISATION

Memory is mapped as a 12-bit block number and a 12-bit offset into that block. The block oriented memory structure permits the use of 16-bit pointers in software, minimising the overhead of accessing memory. The address can be found from the following equation:

address = block_number × 2560 + offset

The sub-CPU sees the SAA7391 as a memory mapped peripheral, with control and status registers appearing in the highest 256 bytes of the external address space (PDATA space).

The phrase (PDATA space) is meant to imply that the code will access registers most efficiently if the PDATA (8051 port P2) pointer is set to point at the register space of the SAA7391. If the PDATA space is better used as context switching space then it can be used for that purpose.

All registers and RAM are accessible in the XDATA space at all times, the PDATA is just a movable 256 byte window with faster access into XDATA.

The lowest 56 kbytes of the 8051 external address data space is mappable as two windows into the memory of 52 kbytes and 4 kbytes, on any user-specified 256 byte boundary within the RAM. This is usable as scratchpad RAM.

The two pages permits the paging of process context information for use with a multi-tasking kernel, while still keeping some global variables.

The next 7.5 kbytes is mapped as a window into memory starting at a user-specified block number. This is usable for accessing block data, subcode information, error corrector status and block headers.

The 64 kbytes memory mapping is shown in Fig.11.

ATAPI CD-R block encoder/decoder

SAA7391

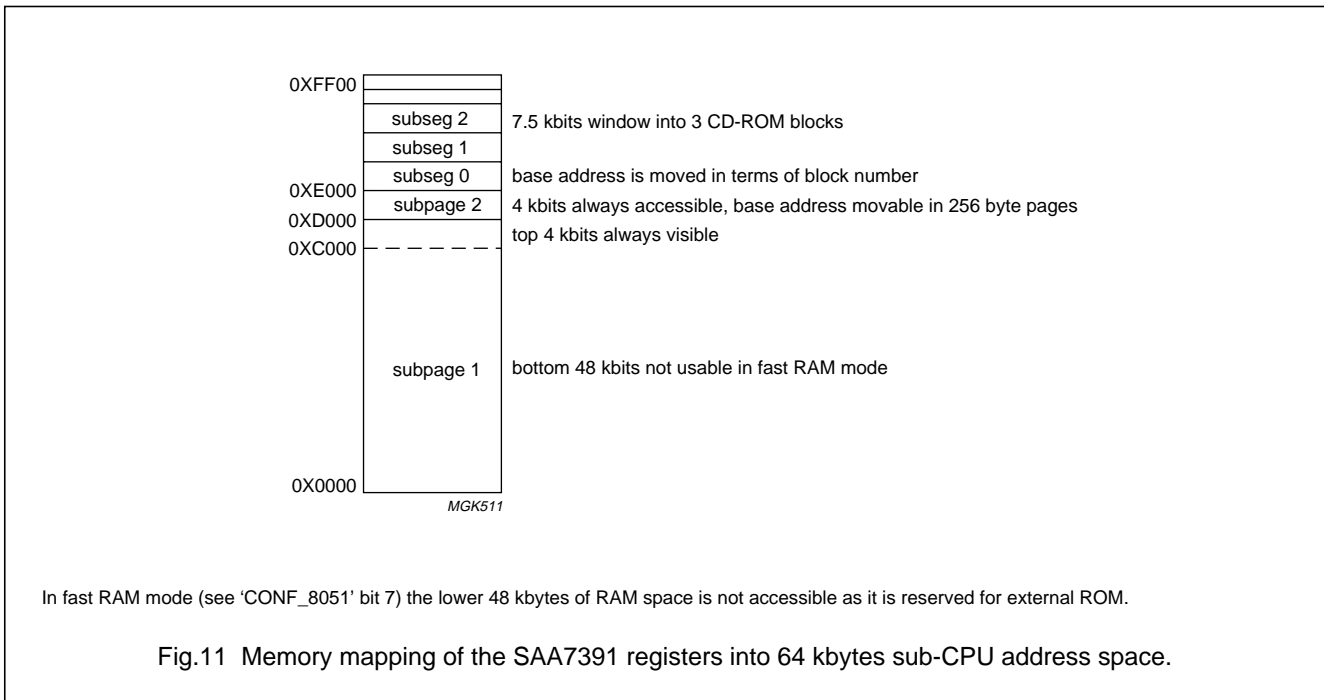

Table 88 The SAA7391 memory map

ADDRESS	SEGMENT SIZE (BYTES)	USED FOR	ADDRESS FUNCTION
FFC0H to FFFFH	64	the SAA7391s dead space	none; note 1
FF00H to FFBFH	192	the SAA7391 register access, debug write to DRAM	none; notes 2 and 3
E000H to FEFH	7936	segments in DRAM	note 4
D000H to DFFFH	4096	subpage 2 in DRAM	note 5
C000H to CFFFH	4096	subpage 1 in DRAM	note 6
0000H to BFFFH	49152	subpage 1 in DRAM	notes 1 and 6

Notes

1. If the SAA7391 is addressed in this area it will not access the DRAM and the data output of the sub-CPU interface to the microcontroller is disabled. If the SAA7391 host interface has been configured for generic mode and the address access from FFC0H to FFDFH, a chip select signal is asserted 'zero' on the output pin XDA1.
2. CPU address (bits 23 to 8) = 0. CPU address (bits 7 to 0) = address (bits 7 to 0).
3. Read in this segment is always from internal the SAA7391 registers. Write is to internal the SAA7391 registers and, optionally, also to DRAM if debug is set (conf_8051, bit 1 = 1).
4. CPU address (bits 8 to 0) = address (bits 8 to 0). CPU address (bits 23 to 9) = subseg 1 (bits 12 to 0) + subseg 1 (12 to 0) × 4 + address (bits 12 to 9).
5. CPU address (bits 9 to 0) = address (bits 9 to 0). CPU address (bits 23 to 10) = subseg 2 (bits 15 to 2) + address (bits 11 and 10).
6. CPU address (bits 9 to 0) = address (bits 9 to 0). CPU address (bits 23 to 10) = subseg 1 (bits 15 to 2) + address (bits 15 to 10).

ATAPI CD-R block encoder/decoder

SAA7391

7.7.3 SUBPAGE

The lowest 52 kbytes (0X000H to 0XCFFFH) of the external data memory is mapped to SUBPAGE1. If the user requires less RAM than is provided here (up to 52 kbytes), the 1024 byte granularity of positioning the offsets permits the pages to be overlapped. In the fast RAM access mode, the lowest 48 kbytes are not accessible as they are assumed to be ROM space.

The next 4 kbytes (0XD000H to 0XDFFFH) of the external data memory is always mapped to SUBPAGE2, and is always available.

Table 89 Subpage RAM offsets

ADDRESS	NAME	BIT 7	BIT 6	BIT 5	BIT 4	BIT 3	BIT 2	BIT 1	BIT 0
FF18H	SUBPAGE1-H	a23	a22	a21	a20	a19	a18	a17	a16
FF19H	SUBPAGE1-L	a15	a14	a13	a12	a11	a10	–	–
FF1AH	SUBPAGE2-H	a23	a22	a21	a20	a19	a18	a17	a16
FF1BH	SUBPAGE2-L	a15	a14	a13	a12	–	a10	–	–

7.7.3.1 Sub-CPU segment page

The sub-CPU may access three adjacent segments of data offset from the base segment pointed to by 'subseg'. These are mapped as a contiguous 7.5 kbytes block at the top of memory from 0XE000 to 0XF800.

The buffer address is formed using the following equation:

$$\text{Buffer address} = \text{subseg (down to 0)} \times 2560 + \text{sub-CPU (a12 down to 0)}$$

This permits the writing of headers and looking at subcode information which may span more than one segment. Linked lists in the 'spare' space at the end of a segment may be more easily manipulated if the segment and its neighbours are visible to the sub-CPU in a consistent manner.

It is also possible to indirectly access any part of RAM by using the block copy registers to move the data to and from the sub-CPU subpages.

7.7.3.2 Sub-CPU segment page restriction

It should be noted that the SAA7391 device does not have the concept of a defined upper limit on the segment addressed block. Hence the segment page is always 3 contiguous segments of RAM, even when near or at the top of accessible RAM or at the top of the firmware defined data input buffer. In this case 1 or 2 of the blocks accessed will be beyond the buffer.

Table 90 Sub-CPU segment RAM offsets

ADDRESS	NAME	BIT 7	BIT 6	BIT 5	BIT 4	BIT 3	BIT 2	BIT 1	BIT 0
FF1CH	SUBSEG-H	s7	s6	s5	s4	s3	s2	s1	s0
FF1DH	SUBSEG-L	–	–	–	–	s11	s10	s9	s8

7.8 External memory interface

The external memory interface is designed to operate with up to 128 Mbits hyper-page 33 MHz DRAM (EDO RAM) It is also designed to operate with fast-page DRAM giving a 17.5 Mbyte/s burst transfer rate. Figures 13 and 14 illustrate the timing diagram for fast-page mode.

It should be noted that during the power-on reset cycle it is necessary to pull the XDATA bus to all zeros to configure the SAA7391 for use with the 8051 microcontroller.

ATAPI CD-R block encoder/decoder

SAA7391

7.8.1 DRAM INTERFACE CONFIGURATION REGISTER

Table 91 DRAM_CONFIG: address FF6AH (see Table 92)

ACCESS	BIT 7	BIT 6	BIT 5	BIT 4	BIT 3	BIT 2	BIT 1	BIT 0
W	–	–	–	feature 4	feature 3	feature 2	feature 1	feature 0

Table 92 Description of the DRAM interface features

feature 4	feature 3	feature 2	feature 1	feature 0	OPTION
0	X	X	X	X	refresh every 256 system clock cycles
1	X	X	X	X	refresh every 511 system clock cycles
X	1	X	X	X	minimum $\overline{\text{RAS}}$ LOW is 2 clock cycles
X	0	X	X	X	minimum $\overline{\text{RAS}}$ LOW is 3 clock cycles
X	X	1	0	X	1 Mbit \times 4 DRAM used
X	X	1	1	X	4 Mbit \times 4 DRAM used
X	X	0	X	X	512 kbits \times 8, 1 Mbit \times 8, 2 Mbits \times 8, 4 Mbits \times 8, 8 Mbits \times 8 or 16 Mbits \times 8 DRAM used
X	X	X	X	0	use fast-page mode device
X	X	X	X	1	use hyper-page mode device

7.9 UART for communication with CD engine

The following are required for communication with the CD engine:

- Clock prescaler for selectable baud rate
- Synchronous slave peripheral interface
- Asynchronous UART
- DMA to reduce sub-CPU loading in SPI mode
- Interrupt options available.

7.9.1 UART BASIC ENGINE INTERFACE

The basic engine interface implements both a synchronous peripheral interface and an asynchronous high-speed serial interface. The same registers are shared between the functions involved. Transmitted and received data in asynchronous mode is sent or received with parity bits in 8-bit, one parity bit, one STOP bit format. The registers that are implemented are described below.

Two 16-bit DMA pointers (SPI_RX_OFF and SPI_TX_OFF) are provided so that the interface may be used in a DMA mode. As a byte is transferred to or from the UART registers, it is possible to copy it into a part of the AUXSEG RAM (16-bit register AUXSEGMENT-H or AUXSEGMENT-L) in the SAA7391s buffer memory.

The pointers auto-increment and wrap within the region assigned, so if the user wishes the data to appear in the

same place in the buffer for each DMA transfer it will be necessary to reload these pointers before re-enabling DMA for the data transfer.

DMA operation can be independently on for the transmit and receive channels.

To enable the DMA receive channel the UART_DMA_CTRL bit 7 must be set to logic 1. When the receive DMA channel is active the sub-CPU cannot read the receive register (RXDATA address FF77H) any more but the SAA7391 will automatically copy the contents of the RXDATA register to the address pointed at by the SPI_RX_OFFSET pointer if it is full, increment the SPI_RX_OFFSET pointer and reset the 'rvbfull' bit.

The SPI offset registers are available in both synchronous and asynchronous modes and not just for SPI.

The SPI_RX_OFFSET register may be read to determine how many bytes have been received.

The polarity of the SPI clock is selectable from the UARTCOM register (see Table 94).

To enable the DMA transmit channel the UART_DMA_CTRL bit 6 must be set to logic 1 and, at the same time, bits 5 to 0 ('txdmaount') must be greater than zero. When the transmit channel is active the sub-CPU can write to the transmit register (TXDATA address FF77H), however, the SAA7391 will automatically perform the following operation.

ATAPI CD-R block encoder/decoder

SAA7391

If (transmit register empty) TRANSMITREG = RAM [AUXSEGMENT × 2560 + SPI_TX_OFFSET]

SPI_TX_OFFSET = SPI_TX_OFFSET + 1

uart_dma_ctrl (5 : 0) = uart_dma_ctrl (5 : 0) – 1 end if;

Transmission will automatically stop when the 'uart_dma_ctrl' (bits 5 to 0) (the 'txdmaount') has incremented to zero. This condition will produce the interrupt.

Data transmission rates are selectable by writing a value n(0 to 255) to the UART_PRE_SCALER register. The baud rate for each mode can then be calculated as follows:

$$\text{For the SPI mode } f_{\text{SPI}} = \frac{f_{\text{sysclk}}}{[2 \times (n + 1)]}$$

$$\text{For the S2B mode } f_{\text{S2B}} = \frac{f_{\text{sysclk}}}{[16 \times (n + 1)]}$$

Table 93 UART general registers

ADDRESS	NAME	BIT 7	BIT 6	BIT 5	BIT 4	BIT 3	BIT 2	BIT 1	BIT 0
FF28H	AUXSEGMENT-H	bit 15	bit 14	bit 13	bit 12	bit 11	bit 10	bit 9	bit 8
FF29H	AUXSEGMENT-L	bit 7	bit 6	bit 5	bit 4	bit 3	bit 2	bit 1	bit 0
FF4AH	SPI_RX_OFF-H	bit 15	bit 14	bit 13	bit 12	bit 11	bit 10	bit 9	bit 8
FF4BH	SPI_RX_OFF-L	bit 7	bit 6	bit 5	bit 4	bit 3	bit 2	bit 1	bit 0
FF4CH	SPI_TX_OFF-H	bit 15	bit 14	bit 13	bit 12	bit 11	bit 10	bit 9	bit 8
FF4DH	SPI_TX_OFF-L	bit 7	bit 6	bit 5	bit 4	bit 3	bit 2	bit 1	bit 0
FF74H	UART_PRE_SCALER (rw)7	prescale value (bits 7 to 0)							
FF75H	UART_DMA_CTRL (rw)	rcvdma on	txdma on	txdmaount (bits 5 to 0)					
FF76H	UARTCOM (w)	paron	spion	–	–	–	–	–	parpol clkpol
FF77H	RXDATA (w)	d7	d6	d5	d4	d3	d2	d1	d0
FF7H	RXDATA (r)	d7	d6	d5	d4	d3	d2	d1	d0
FF78H	UARTTINTSTAT/RESET (rw)	comsync	syssync	not comsync	not syssync	not txbfull	rvbfull	overrun	rvparity
FF79H	UARTTINTEN (w)	comsyn	syssync	not comsync	not syssync	not txbfull	rvbfull	overrun	rvparity
FF7EH	UARTSTAT (r) ⁽¹⁾	comsync	syssync	comsync	syssync	txbfull	rxbfull	overrun	rxparity
FF7FH	UARTAUXSTAT (r) ⁽²⁾	comiack	txfull	rxfull	–	–	–	–	–

Notes

1. See Table 95.
2. See Table 96.

ATAPI CD-R block encoder/decoder

SAA7391

Table 94 Description of the UARTCOM register bits

BIT	NAME	VALUE	DESCRIPTION
7	paron	0	disable parity bit in S2B mode
		1	enable parity bit in S2B mode
6	spion	0	S2B transmission mode
		1	SPI transmission mode
0	parpol clkpol	0	SPI clock active LOW; S2B even parity
		1	SPI clock active HIGH; S2B odd parity

Table 95 Description of the UARTSTAT register bits

BIT	NAME	VALUE	DESCRIPTION
7	comsync	0	comsync pin level
		1	
6	sysync	0	sysync pin level
		1	
5	comsync	0	inverted comsync pin level
		1	
4	sysync	0	inverted sysync pin level
		1	
3	txbfull	0	–
		1	transmit data buffer is empty and ready for another byte
2	rxbfull	0	receive data buffer is not valid
		1	receive data buffer is valid
1	overrun	0	–
		1	a byte was lost because the 'rxdata' register was not read in time
0	rxparity	0	–
		1	received parity bit is in error

Table 96 Description of the UARTAUXSTAT register bits

BIT	NAME	VALUE	DESCRIPTION
7	comiack	0	comiack pin level
		1	
6	txfull	0	–
		1	transmit register is full (a byte is being sent)
5	rxfull	0	–
		1	receive register holds a byte, need to read a byte immediately to avoid overrun

Table 97 CD playback error rate measurement registers

ADDRESS	NAME	BIT 7	BIT 6	BIT 5	BIT 4	BIT 3	BIT 2	BIT 1	BIT 0
FF11H	C1BLERCNT	d7	d6	d5	d4	d3	d2	d1	d0
FF12H	C2BLERCNT	d7	d6	d5	d4	d3	d2	d1	d0

ATAPI CD-R block encoder/decoder

SAA7391

7.10 Clock generation control

7.10.1 CRYSTAL OSCILLATOR

The crystal oscillator is a conventional 2-pin inverting design operating from 8 to 35 MHz; this oscillator is also capable of operating with a 33.8 MHz ceramic resonator. It is capable of oscillating with both fundamental and 3rd-overtone mode crystals. External components should be used to suppress the fundamental output of the 3rd-overtone types as shown in Fig.12. When operating with lower frequency crystals, R_s must be greater than 0Ω to avoid overdriving the crystal.

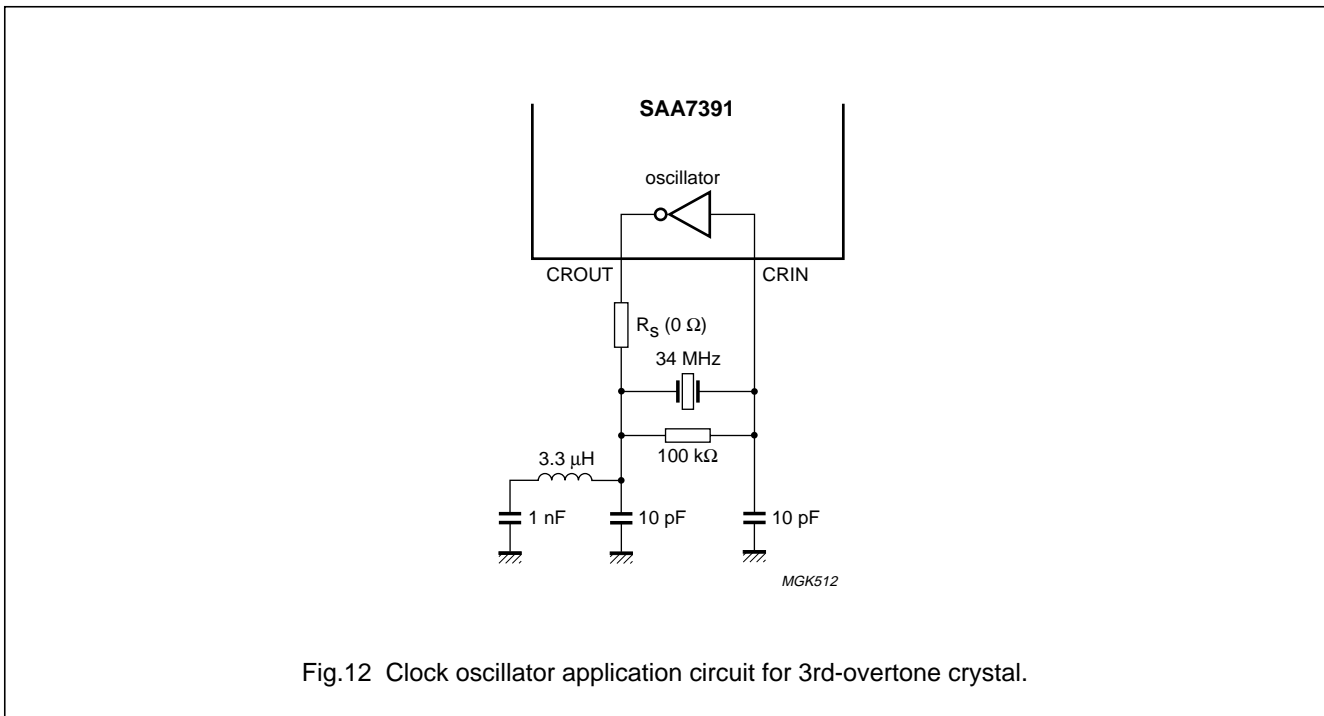

Fig.12 Clock oscillator application circuit for 3rd-overtone crystal.

ATAPI CD-R block encoder/decoder

SAA7391

7.10.2 SUB-CPU CLOCK CONTROL REGISTER

This register controls the clocking of the sub-CPU and the generation of wait states, ensuring a low jitter in the clock while allowing wait states.

Table 98 CONF_8051: address FF73H (see Table 99)

BIT 7	BIT 6	BIT 5	BIT 4	BIT 3	BIT 2	BIT 1	BIT 0
modsel	wait2	wait1	wait0	div2	div1	div0	debug

Table 99 Description of the CONF_8051 register bits

BIT	NAME	VALUE	DESCRIPTION
7	modsel	0	wait state control
		1	
6 to 4	wait2 to wait0	000	0 wait states
		001	1 wait state
		010	2 wait states
		011	3 wait states
		100	4 wait states
		101	5 wait states
		110	6 wait states
		111	7 wait states
3 to 1	div2 to div0	000	8051 clock is sysclk; note 1
		001	8051 clock is sysclk/1.5; note 1
		010	8051 clock is sysclk/2
		011	8051 clock is sysclk/3
		100	8051 clock is sysclk/4
		1XX	undefined
0	debug	0	–
		1	register writes are shadowed through into buffer RAM

Note

- The clock pulse provided to the 8051 is equal to the HIGH period of sysclk for divide-by-1 and divide-by-1.5. For all other division ratios the clock pulse HIGH time is equal to one cycle of sysclk.

7.10.3 SAA7391 SYSTEM CLOCK CONTROL REGISTERS

Table 100 CLK_CON register

ADDRESS	NAME	BIT 7	BIT 6	BIT 5	BIT 4	BIT 3	BIT 2	BIT 1	BIT 0
FF9EH	MULTI_CON	mode	m6	m5	m4	m3	m2	m1	m0
FF9FH	CLK_CON ⁽¹⁾	pll pwr	pll ena	–	–	–	–	xtal1	xtal0

Note

- Write operations to bit 6 of CLK_CON register may become unreliable once this bit has been written to with a logic 1.

ATAPI CD-R block encoder/decoder

SAA7391

Table 101 Description of the CLK_CON register bits

BIT	NAME	VALUE	DESCRIPTION	f _{PLL} (kHz)	NOTES
7	pll _{pwr}	0	PLL is powered-down	–	default
		1	PLL is powered-up	–	–
6	pll _{ena}	0	system clock source is CRIN	–	default
		1	system clock source is from clock multiplier	–	–
1 and 0	xtal1 and xtal0	00	crystal is 8.4672 MHz; divide-by-16	529.2	–
		01	crystal is 11.289 MHz; divide-by-22	513.1	–
		10	crystal is 16.9344 MHz; divide-by-32	529.2	default
		11	crystal is 33.8688 MHz; divide-by-64	529.2	–

Table 102 The relationship between the values of the m bits and VCO frequency for a normalised PLL frequency of 500 kHz; note 1

m6 to m0 (HEX)	FREQUENCY (MHz)	m6 to m0 (HEX)	FREQUENCY (MHz)
02	3	58	29
04	4	30	30
08	5	60	31
11	6	41	32
22	7	03	33
44	8	06	34
09	9	0C	35
13	10	19	36
26	11	33	37
4C	12	66	38
18	13	4D	39
31	14	1A	40
62	15	35	41
45	16	6A	42
0B	17	54	43
17	18	29	44
2E	19	53	45
5D	20	27	46
3A	21	4E	47
75	22	1C	48
6B	23	39	49
56	24	73	50
2D	25	67	51
5B	26	4F	52
36	27	1E	53
6C	28	3D	54

ATAPI CD-R block encoder/decoder

SAA7391

m6 to m0 (HEX)	FREQUENCY (MHz)
7B	55
76	56
6D	57
5A	58
34	59
68	60
50	61
21	62
42	63
05	64
0A	65
15	66
2A	67
55	68
2B	69
57	70
2F	71
5F	72
3E	73
7D	74
7A	75
74	76
69	77
52	78
25	79
4A	80
14	81
28	82
51	83
23	84
46	85
0D	86
1B	87
37	88
6E	89
5C	90
38	91
71	92
63	93
47	94

m6 to m0 (HEX)	FREQUENCY (MHz)
0F	95
1F	96
3F	97
7F	98
7E	99
7C	100
78	101
70	102
61	103
43	104
07	105
0E	106
1D	107
3B	108
77	109
6F	110
5E	111
3C	112
79	113
72	114
65	115
4B	116
16	117
2C	118
59	119
32	120
64	121
49	122
12	123
24	124
48	125
10	126
20	127
40	128

Note

1. It should be noted that the mode bit (MSB high byte) has not been included in the table. The oscillator output frequency can be determined by dividing the VCO frequency given in Table 102 according to the mode bit described in Table 103.

ATAPI CD-R block encoder/decoder

SAA7391

Table 103 Explanation of mode bit

MODE BIT	DIVISION RATIO
0	divide the frequency from Table 102 by 4 to obtain 'sysclk' frequency
1	divide the frequency from Table 102 by 2 to obtain 'sysclk' frequency

8 LIMITING VALUES

In accordance with the Absolute Maximum Rating System (IEC 134)

SYMBOL	PARAMETER	MIN.	TYP.	UNIT
$V_{DDD(\text{core})}$	core digital supply voltage	-0.5	+4.5	V
$V_{DDD(\text{pad})}$	periphery digital supply voltage	-0.5	+6.5	V
V_{DDA}	analog supply voltage	-0.5	+4.6	V
$V_{i(\text{max})}$	maximum voltage on any input	-0.5	$V_{DDD(\text{pad})} + 0.5$	V
V_o	output voltage on any output	-0.5	+6.5	V
I_o	output current (continuous)	-	20	mA
P	power dissipation	-	400	mW
T_{stg}	storage temperature	-55	+125	°C
T_{amb}	operating ambient temperature	0	70	°C

9 THERMAL CHARACTERISTICS

SYMBOL	PARAMETER	CONDITIONS	VALUE	UNIT
$R_{\text{thj-a}}$	thermal resistance from junction to ambient	in free air	55	K/W

10 CHARACTERISTICS

SYMBOL	PARAMETER	CONDITIONS	MIN.	TYP.	MAX.	UNIT
Digital Inputs						
INPUTS DESIGNATED BY 'C' (CMOS VOLTAGE LEVELS)						
V_{IL}	LOW-level input voltage		-0.3	-	$0.3V_{\text{DDD}(\text{pad})}$	V
V_{IH}	HIGH-level input voltage		$0.7V_{\text{DDD}(\text{pad})}$	-	$V_{\text{DDD}(\text{pad})} + 0.3$	V
I_{LI}	input leakage current	$V_i = 0$ to $V_{\text{DDD}(\text{pad})}$	-10	-	10	μA
C_i	input capacitance		-	-	10	pF
INPUTS DESIGNATED BY 'T' (TTL VOLTAGE LEVELS)						
V_{IL}	LOW-level input voltage		-0.3	-	0.8	V
V_{IH}	HIGH-level input voltage		2.0	-	$V_{\text{DDD}(\text{pad})} + 0.3$	V
I_{LI}	input leakage current	$V_i = 0$ to $V_{\text{DDD}(\text{pad})}$	-10	-	10	μA
C_i	input capacitance		-	-	10	pF

ATAPI CD-R block encoder/decoder

SAA7391

SYMBOL	PARAMETER	CONDITIONS	MIN.	TYP.	MAX.	UNIT
$\overline{\text{POR}}$ AND $\overline{\text{RESET}}$ (SCHMITT TRIGGER)						
$V_{\text{th(POS)}}$	Schmitt trigger positive-going switching threshold voltage		–	–	$0.8V_{\text{DDD(pad)}}$	V
$V_{\text{th(NEG)}}$	Schmitt trigger negative-going switching threshold voltage		$0.2V_{\text{DDD(pad)}}$	–	–	V
V_{hys}	hysteresis voltage		1.0	–	–	V
C_i	input capacitance		–	–	3	pF
Digital Outputs						
OUTPUTS DESIGNATED BY 'L' (CMOS LEVELS)						
V_{OL}	LOW-level output voltage	$I_{\text{OL}} = 2 \text{ mA}$	0	–	0.4	V
V_{OH}	HIGH-level output voltage	$I_{\text{OH}} = -2 \text{ mA}$	$V_{\text{DDD(pad)}} - 0.4$	–	V_{DDD}	V
C_L	load capacitance		–	–	20	pF
$t_{\text{O(r)}}$	output rise time	$C_L = 20 \text{ pF};$ 10% to 90%	–	–	10	ns
$t_{\text{O(f)}}$	output fall time	$C_L = 20 \text{ pF};$ 90% to 10%	–	–	10	ns
OUTPUTS DESIGNATED BY 'M' (CMOS LEVELS)						
V_{OL}	LOW-level output voltage	$I_{\text{OL}} = 4 \text{ mA}$	0	–	0.4	V
V_{OH}	HIGH-level output voltage	$I_{\text{OH}} = -4 \text{ mA}$	$V_{\text{DDD(pad)}} - 0.4$	–	V_{DDD}	V
C_L	load capacitance		–	–	20	pF
$t_{\text{O(r)}}$	output rise time	$C_L = 20 \text{ pF};$ 10% to 90%	–	–	8	ns
$t_{\text{O(f)}}$	output fall time	$C_L = 20 \text{ pF};$ 90% to 10%	–	–	8	ns
OUTPUTS DESIGNATED BY 'H' (CMOS LEVELS)						
V_{OL}	LOW-level output voltage	$I_{\text{OL}} = 8 \text{ mA}$	0	–	0.4	V
V_{OH}	HIGH-level output voltage	$I_{\text{OH}} = -8 \text{ mA}$	$V_{\text{DDD(pad)}} - 0.4$	–	V_{DDD}	V
C_L	load capacitance		–	–	20	pF
$t_{\text{O(r)}}$	output rise time	$C_L = 20 \text{ pF};$ 10% to 90%	–	–	6	ns
$t_{\text{O(f)}}$	output fall time	$C_L = 20 \text{ pF};$ 90% to 10%	–	–	6	ns
OUTPUTS: DESIGNATED BY 'AL' (ATA DATA BUS LEVELS)						
V_{OL}	LOW-level output voltage	$I_{\text{OL}} = 4 \text{ mA}$	0	–	0.4	V
V_{OH}	HIGH-level output voltage	$I_{\text{OH}} = -4 \text{ mA}$	2.4	–	V_{DDD}	V
C_L	load capacitance		–	–	100	pF
$t_{\text{O(r)}}$	output rise time	$C_L = 40 \text{ pF};$ 10% to 90%	5	–	–	ns
$t_{\text{O(f)}}$	output fall time	$C_L = 40 \text{ pF};$ 90% to 10%	5	–	–	ns

ATAPI CD-R block encoder/decoder

SAA7391

SYMBOL	PARAMETER	CONDITIONS	MIN.	TYP.	MAX.	UNIT
OUTPUTS: DESIGNATED BY 'AH' (ATA LEVELS)						
V _{OL}	LOW-level output voltage	I _{OL} = 12 mA	0	–	0.4	V
V _{OH}	HIGH-level output voltage	I _{OH} = –4 mA	2.4	–	V _{DDD}	V
C _L	load capacitance		–	–	100	pF
t _{o(r)}	output rise time	C _L = 40 pF; 10% to 90%	5	–	–	ns
t _{o(f)}	output fall time	C _L = 40 pF; 90% to 10%	5	–	–	ns
Crystal oscillator input: CRIN						
f _{CLK}	external clock frequency		8	8.4677	35	MHz
V _{IL}	LOW-level input voltage		–0.3	–	0.3V _{DDD(core)}	V
V _{IH}	HIGH-level input voltage		0.7V _{DDD(core)}	–	V _{DDD(C)} + 0.3	V
I _{LI}	input leakage current		–10	–	10	μA
C _i	input capacitance		–	–	10	pF
Crystal oscillator output: CROUT						
f _{xtal}	crystal frequency		–	–	35	MHz
g _m	transconductance		16	–	–	mσ
R _o	output resistance		–	–	–	
G _v	small signal voltage gain	G _v = g _m × R _o	5	–	–	V/V
C _{fb}	feedback capacitance		–	–	5	pF
C _o	output capacitance		–	–	10	pF

ATAPI CD-R block encoder/decoder

SAA7391

11 TIMING CHARACTERISTICS

11.1 External memory interface timing

Table 104 DRAM interface timing (fast-page mode); see Figs 13 and 14 and note 1

SYMBOL	PARAMETER	CONDITIONS	MIN.	MAX.	UNIT
T_{cy}	read or write cycle period		160	–	ns
$t_{ACC(CAS)}$	access time from \overline{CAS}		–	20	ns
$t_{ACC(RAS)}$	access time from \overline{RAS}		–	–	ns
t_{RASH}	\overline{RAS} HIGH time		70	–	ns
t_{RASL}	\overline{RAS} LOW time		80	10000	ns
$t_{h(RAS)}$	\overline{RAS} hold time		20	–	ns
t_{CASL}	\overline{CAS} LOW time		20	10000	ns
$t_{h(CAS)}$	\overline{CAS} hold time		80	–	ns
$t_{d(CASH-RAS)}$	delay time \overline{CAS} HIGH to \overline{RAS}		10	–	ns
$t_{d(RAS-CAS)}$	\overline{RAS} to \overline{CAS} delay time		25	–	ns
$t_{d(RAS-CA)}$	\overline{RAS} to column address delay time		20	–	ns
$t_{su(RA)}$	row address set-up time		0	–	ns
$t_{h(RA)}$	row address hold time		15	–	ns
$t_{su(CA)}$	column address set-up time		0	–	ns
$t_{h(CA)}$	column address hold time		20	–	ns
$t_{h(CA-RASL)}$	column address hold time from \overline{RAS} LOW		60	–	ns
$t_{l(CA-RAS)}$	column address to \overline{RAS} lead time		40	–	ns
$t_{h(R)}$	read command hold time		0	–	ns
$t_{h(R-RAS)}$	read command hold time from \overline{RAS}		60	–	ns
$t_{su(W)}$	write command set-up time		0	–	ns
$t_{h(W)}$	write command hold time		15	–	ns
t_{WL}	write command LOW time		15	–	ns
$t_{h(W-RAS)}$	write command hold time from \overline{RAS}		60	–	ns
$t_{l(W-CAS)}$	write command to \overline{CAS} lead time		20	–	ns
$t_{l(W-RAS)}$	write command to \overline{RAS} lead time		20	–	ns
$t_{su(DO)}$	data output set-up time		0	–	ns
$t_{h(DO)}$	data output hold time		15	–	ns
$t_{h(DO-RAS)}$	data output hold time from \overline{RAS}		60	–	ns

Note

1. For further information regarding the DRAM timing please consult the device user manual or contact product support.

ATAPI CD-R block encoder/decoder

SAA7391

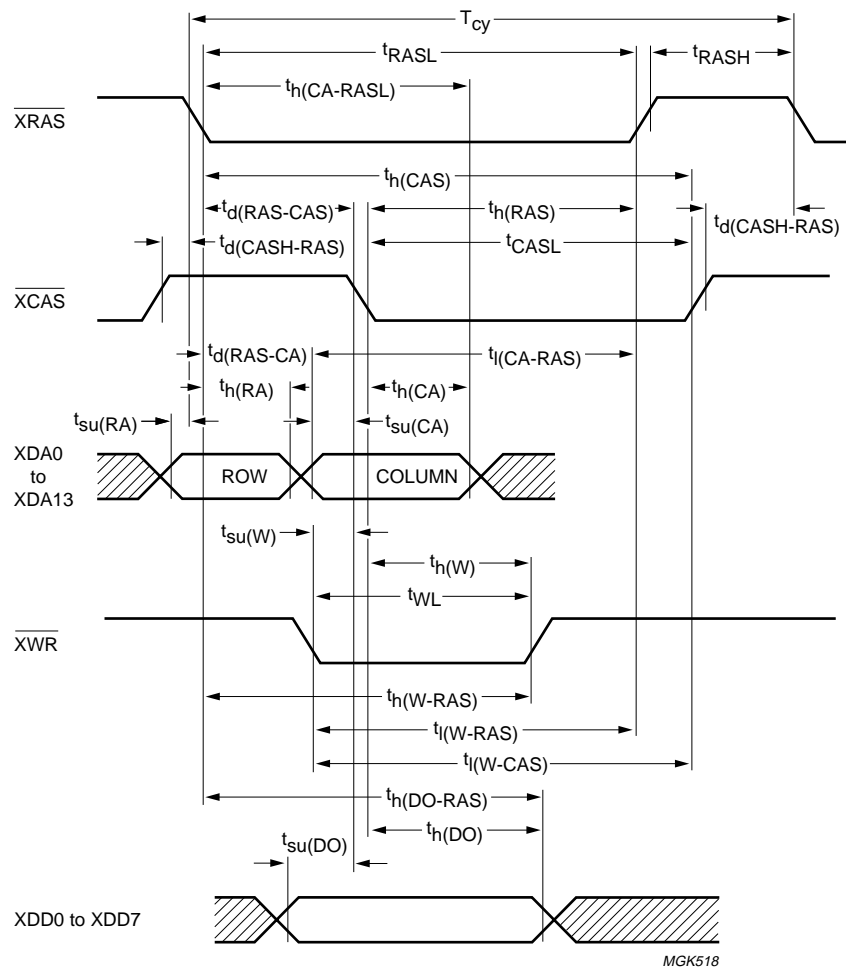

Fig.13 External DRAM write cycle timing for fast-page.

ATAPI CD-R block encoder/decoder

SAA7391

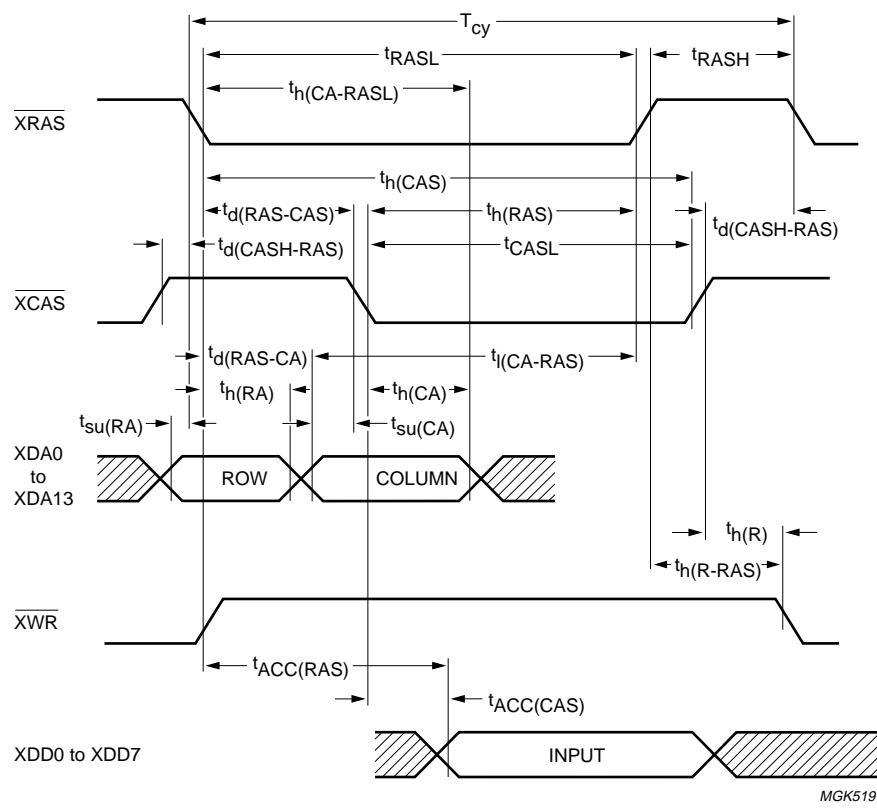

Fig.14 External DRAM read cycle timing for fast-page.

ATAPI CD-R block encoder/decoder

SAA7391

11.2 Host interface timing

This section deals with the implemented timings of the SAA7391 host interface in both the ATAPI and generic interface modes. The timings of the ATAPI PIO Mode 3 and Mode 4 are also taken into account.

Table 105 Basic AC characteristics, ATA bus

SYMBOL	PARAMETER	CONDITIONS	MIN.	MAX.	UNIT
t_r	rise time for any signal on ATAPI interface	10 to 90% of full signal amplitude with a total capacitive load of 100 pf	5	–	ns
t_f	fall time for any signal on ATAPI interface	10 to 90% of full signal amplitude with a total capacitive load of 100 pf	5	–	ns
C_i	input capacitance for each host or device		–	25	pf
C_o	output capacitance for each host or device		–	25	pf

11.2.1 HOST INTERFACE ATAPI PIO AND DMA TIMING

This section deals with the implemented timings of the SAA7391 host interface in both the ATAPI and generic interface modes. The timings of the ATAPI PIO Mode 3 and Mode 4 are also taken into account (see Table 105).

ATAPI CD-R block encoder/decoder

SAA7391

11.2.2 ATA BUS TIMING

The figures and timing characteristics detail the timing as specified in the ATA-3 documentation.

Table 106 Timing of PIO data transfer to and from device; see Fig.15

SYMBOL	PARAMETER	CONDITIONS	MIN.	MAX.	UNIT
T_{cy}	cycle time	note 1			
		Mode 0	600	–	ns
		Mode 1	383	–	ns
		Mode 2	240	–	ns
		Mode 3	180	–	ns
		Mode 4	120	–	ns
$t_{su(A-DIOR/DIOW)}$	address valid to $\overline{DIOR/DIOW}$ set-up time	Mode 0	70	–	ns
		Mode 1	50	–	ns
		Mode 2	30	–	ns
		Mode 3	30	–	ns
		Mode 4	25	–	ns
$t_{W(DIOR/DIOW)}$	$\overline{DIOR/DIOW}$ pulse width	16-bit; note 1			
		Mode 0	165	–	ns
		Mode 1	125	–	ns
		Mode 2	100	–	ns
		Mode 3	80	–	ns
		Mode 4	70	–	ns
		8-bit; note 1			
		Mode 0	290	–	ns
		Mode 1	290	–	ns
		Mode 2	290	–	ns
		Mode 3	80	–	ns
Mode 4	70	–	ns		
$t_{rec(DIOR/DIOW)}$	$\overline{DIOR/DIOW}$ recovery time	note 1			
		Mode 0	–	–	ns
		Mode 1	–	–	ns
		Mode 2	–	–	ns
		Mode 3	70	–	ns
		Mode 4	25	–	ns
$t_{su(DIOW)}$	\overline{DIOW} data set-up time	Mode 0	60	–	ns
		Mode 1	45	–	ns
		Mode 2	30	–	ns
		Mode 3	30	–	ns
		Mode 4	20	–	ns

ATAPI CD-R block encoder/decoder

SAA7391

SYMBOL	PARAMETER	CONDITIONS	MIN.	MAX.	UNIT
$t_{h(DIOW)}$	\overline{DIOW} data hold time	Mode 0	30	–	ns
		Mode 1	20	–	ns
		Mode 2	15	–	ns
		Mode 3	10	–	ns
		Mode 4	10	–	ns
$t_{su(DIOR)}$	\overline{DIOR} data set-up time	Mode 0	50	–	ns
		Mode 1	35	–	ns
		Mode 2	20	–	ns
		Mode 3	20	–	ns
		Mode 4	20	–	ns
$t_{h(DIOR)}$	\overline{DIOR} data hold time	Mode 0	5	–	ns
		Mode 1	5	–	ns
		Mode 2	5	–	ns
		Mode 3	5	–	ns
		Mode 4	5	–	ns
$t_{z(DIOR)}$	\overline{DIOR} data 3-state	note 2			
		Mode 0	–	30	ns
		Mode 1	–	30	ns
		Mode 2	–	30	ns
		Mode 3	–	30	ns
$t_{ass(A-IOCS16)}$	address valid to $\overline{IOCS16}$ assertion time	note 3			
		Mode 0	–	90	ns
		Mode 1	–	50	ns
		Mode 2	–	40	ns
		Mode 3	–	–	ns
$t_{rel(A-IOCS16)}$	address valid to $\overline{IOCS16}$ released time	note 3			
		Mode 0	–	60	ns
		Mode 1	–	45	ns
		Mode 2	–	30	ns
		Mode 3	–	–	ns
$t_{h(DIOR/DIOW-A)}$	$\overline{DIOR/DIOW}$ to address valid hold time	Mode 0	20	–	ns
		Mode 1	15	–	ns
		Mode 2	10	–	ns
		Mode 3	10	–	ns
		Mode 4	10	–	ns

ATAPI CD-R block encoder/decoder

SAA7391

SYMBOL	PARAMETER	CONDITIONS	MIN.	MAX.	UNIT
$t_{R(DAT-IORDY)}$	read data valid to \overline{IORDY} active (if \overline{IORDY} initially LOW after $t_{su(IORDY)}$)	Mode 0	0	–	ns
		Mode 1	0	–	ns
		Mode 2	0	–	ns
		Mode 3	0	–	ns
		Mode 4	0	–	ns
$t_{su(IORDY)}$	\overline{IORDY} set-up time	note 4			
		Mode 0	35	–	ns
		Mode 1	35	–	ns
		Mode 2	35	–	ns
		Mode 3	35	–	ns
$t_{W(IORDY)}$	\overline{IORDY} pulse width	Mode 0	–	1250	ns
		Mode 1	–	1250	ns
		Mode 2	–	1250	ns
		Mode 3	–	1250	ns
		Mode 4	–	1250	ns

Notes

1. T_{cy} is the minimum total cycle time, $t_{W(DIOR/DIOW)}$ is the minimum command active time, and $t_{rec(DIOR/DIOW)}$ is the minimum command recovery time or command inactive time. The actual cycle time equals the sum of the actual command active time and the actual command inactive time. The three timing requirements of T_{cy} , $t_{W(DIOR/DIOW)}$, and $t_{rec(DIOR/DIOW)}$ shall be met. The minimum total cycle time requirements is greater than the sum of $t_{W(DIOR/DIOW)}$ and $t_{rec(DIOR/DIOW)}$. This means a host implementation can lengthen either or both $t_{W(DIOR/DIOW)}$ or $t_{rec(DIOR/DIOW)}$ to ensure that T_{cy} is equal to or greater than the value reported in the devices identify drive data. A device implementation shall support any legal host implementation.
2. This parameter specifies the time from the negation edge of \overline{DIOR} to the time that the data bus is no longer driven by the device (3-state).
3. The delay from the activation of \overline{DIOR} or \overline{DIOW} until the state of \overline{IORDY} is first sampled. If \overline{IORDY} is inactive then the host shall wait until \overline{IORDY} is active before the PIO cycle can be completed. If the device is not driving \overline{IORDY} negated at the $t_{su(IORDY)}$ after the activation of \overline{DIOR} or \overline{DIOW} , then $t_{su(DIOR)}$ shall be met and $t_{R(DAT-IORDY)}$ is not applicable. If the device is driving \overline{IORDY} negated at the time $t_{su(IORDY)}$ after the activation of \overline{DIOR} or \overline{DIOW} , then $t_{R(DAT-IORDY)}$ shall be met and $t_{su(DIOR)}$ is not applicable.
4. $t_{ass(A-IOCS16)}$ and $t_{rel(A-IOCS16)}$ apply only to Modes 0, 1 and 2. This signal is not valid for other modes.

ATAPI CD-R block encoder/decoder

SAA7391

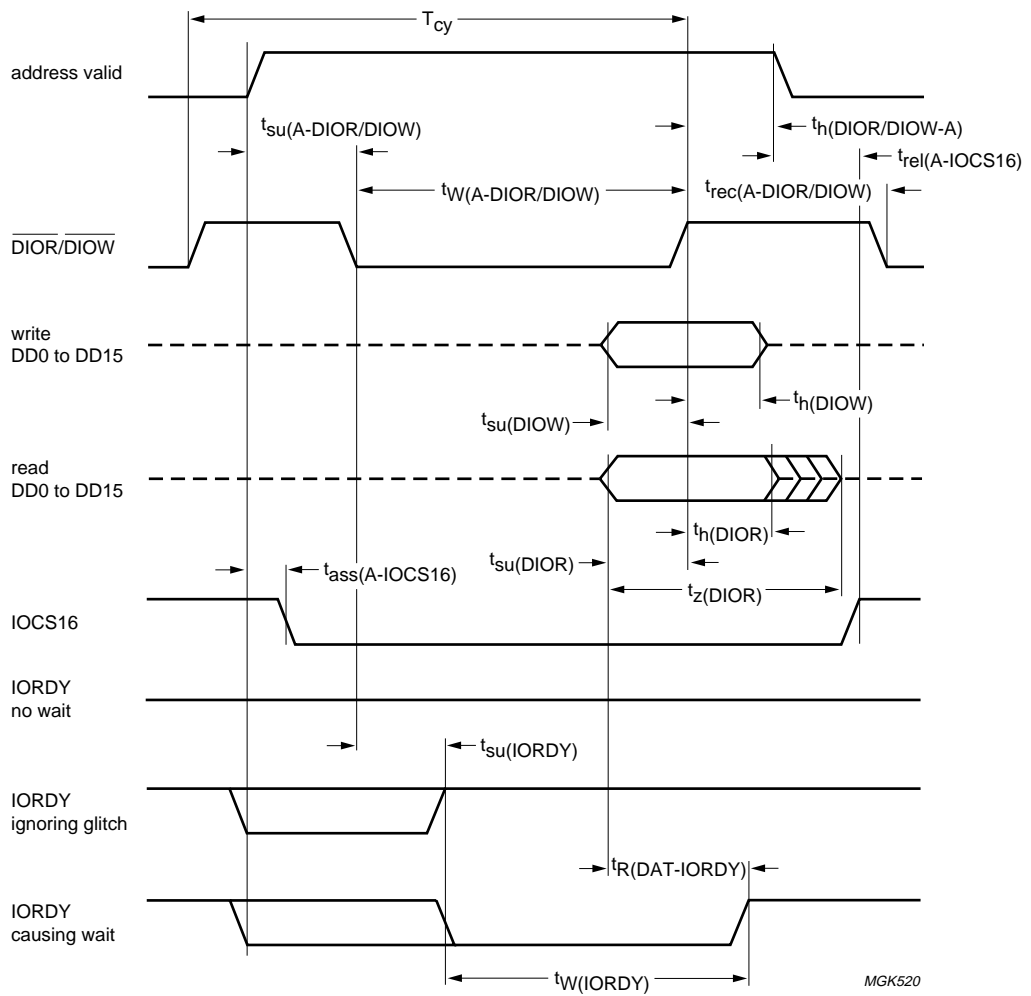

Fig.15 ATA bus timing diagram.

ATAPI CD-R block encoder/decoder

SAA7391

Table 107 Single word DMA timing; see Fig.16

SYMBOL	PARAMETER	CONDITIONS	MIN.	MAX.	UNIT
T_{cy}	cycle time	Mode 0	960	–	ns
		Mode 1	480	–	ns
		Mode 2	240	–	ns
$t_{d(DMACK-DMARQ)}$	DMACK to DMARQ delay	Mode 0	–	200	ns
		Mode 1	–	100	ns
		Mode 2	–	80	ns
$t_{W(DIOR/DIOW)}$	DIOR/DIOW pulse width 16-bit	Mode 0	480	–	ns
		Mode 1	240	–	ns
		Mode 2	120	–	ns
$t_{ACC(DIOR)}$	DIOR data access time	Mode 0	–	250	ns
		Mode 1	–	150	ns
		Mode 2	–	60	ns
$t_{h(DIOR)}$	DIOR data hold time	Mode 0	5	–	ns
		Mode 1	5	–	ns
		Mode 2	5	–	ns
$t_{su(DIOW)}$	DIOW data set-up time	Mode 0	250	–	ns
		Mode 1	100	–	ns
		Mode 2	35	–	ns
$t_{h(DIOW)}$	DIOW data hold time	Mode 0	50	–	ns
		Mode 1	30	–	ns
		Mode 2	20	–	ns
$t_{su(DMACK-DIOR/DIOW)}$	DMACK to DIOR/DIOW set-up time	Mode 0	0	–	ns
		Mode 1	0	–	ns
		Mode 2	0	–	ns
$t_{h(DIOR/DIOW-DMACK)}$	DIOR/DIOW to DMACK hold time	Mode 0	0	–	ns
		Mode 1	0	–	ns
		Mode 2	0	–	ns
$t_{su(DIOR)}$	DIOR set-up time	Mode 0	$t_{W(DIOR/DIOW)} - t_{ACC(DIOR)}$	–	ns
		Mode 1	$t_{W(DIOR/DIOW)} - t_{ACC(DIOR)}$	–	ns
		Mode 2	$t_{W(DIOR/DIOW)} - t_{ACC(DIOR)}$	–	ns

ATAPI CD-R block encoder/decoder

SAA7391

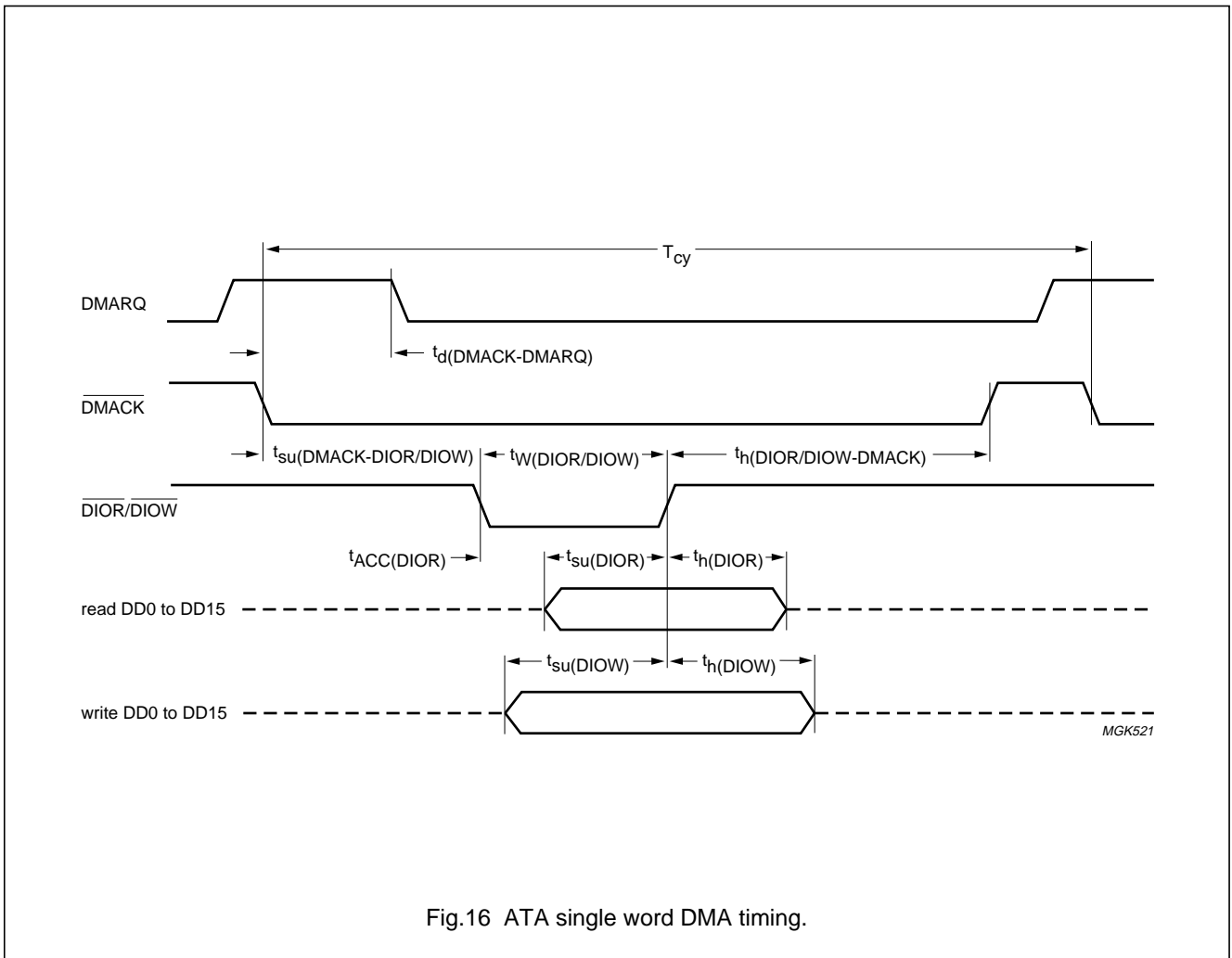

Fig.16 ATA single word DMA timing.

ATAPI CD-R block encoder/decoder

SAA7391

Table 108 Multi-word DMA timing; see Fig.17

SYMBOL	PARAMETER	CONDITIONS	MIN.	MAX.	UNIT
T_{cy}	cycle time	note 1			
		Mode 0	480	–	ns
		Mode 1	150	–	ns
		Mode 2	120	–	ns
$t_{W(DIOR/DIOW)}$	$\overline{DIOR/DIOW}$ pulse width 16-bit	Mode 0	215	–	ns
		Mode 1	80	–	ns
		Mode 2	70	–	ns
$t_{ACC(DIOR)}$	\overline{DIOR} data access time	Mode 0	–	150	ns
		Mode 1	–	60	ns
		Mode 2	–	–	ns
$t_{h(DIOR)}$	\overline{DIOR} data hold time	note 2			
		Mode 0	5	–	ns
		Mode 1	5	–	ns
		Mode 2	5	–	ns
$t_{su(DIOW)}$	\overline{DIOW} data set-up time	Mode 0	100	–	ns
		Mode 1	30	–	ns
		Mode 2	20	–	ns
$t_{h(DIOW)}$	\overline{DIOW} data hold time	Mode 0	20	–	ns
		Mode 1	15	–	ns
		Mode 2	10	–	ns
$t_{su(DMACK-DIOR/DIOW)}$	\overline{DMACK} to $\overline{DIOR/DIOW}$ set-up time	Mode 0	0	–	ns
		Mode 1	0	–	ns
		Mode 2	0	–	ns
$t_{h(DIOR/DIOW-DMACK)}$	$\overline{DIOR/DIOW}$ to \overline{DMACK} hold time	Mode 0	20	–	ns
		Mode 1	5	–	ns
		Mode 2	5	–	ns
$t_{Wneg(DIOR)}$	\overline{DIOR} negated pulse width	note 1			
		Mode 0	50	–	ns
		Mode 1	50	–	ns
$t_{Wneg(DIOW)}$	\overline{DIOW} negated pulse width	note 1			
		Mode 0	215	–	ns
		Mode 1	50	–	ns
$t_{d(DIOR-DMARQ)}$	delay time from \overline{DIOR} to \overline{DMARQ}	Mode 0	–	120	ns
		Mode 1	–	40	ns
		Mode 2	–	35	ns
$t_{d(DIOW-DMARQ)}$	delay time from \overline{DIOW} to \overline{DMARQ}	Mode 0	–	40	ns
		Mode 1	–	40	ns
		Mode 2	–	35	ns

ATAPI CD-R block encoder/decoder

SAA7391

SYMBOL	PARAMETER	CONDITIONS	MIN.	MAX.	UNIT
$t_{d(DMACK-z)}$	delay time from \overline{DMACK} to 3-state	note 2 Mode 0 Mode 1 Mode 2	– – –	20 25 25	ns ns ns

Notes

1. T_{cy} is the minimum total cycle time, $t_{W(DIOR/DIOW)}$ is the minimum command active time, and $t_{Wneg(DIOR)}$ or $t_{Wneg(DIOW)}$, as appropriate) is the minimum command recovery time or command inactive time. The actual cycle time equals the sum of the actual command active time and the actual command inactive time. The three timing requirements of T_{cy} , $t_{W(DIOR/DIOW)}$ and $t_{Wneg(DIOR)}$ or $t_{Wneg(DIOW)}$ shall be met. The minimum total cycle time requirement, T_{cy} , is greater than the sum of $t_{W(DIOR/DIOW)}$ and $t_{Wneg(DIOR)}$ or $t_{Wneg(DIOW)}$. This means a host implementation can lengthen either or both $t_{W(DIOR/DIOW)}$ or $t_{Wneg(DIOR)}$ or $t_{Wneg(DIOW)}$ to ensure that T_{cy} is equal to the value reported in the devices identify drive data. A device implementation shall support any legal host implementation.
2. The original ATA standard defined a maximum value for $t_{h(DIOR)}$. The meaning of this value was not clear. This parameter has been renamed to $t_{d(DMACK-z)}$ and specifies the time from the negation edge of \overline{DMACK} to the time the device data signals are no longer driven by the device (3-state). The $t_{d(DMACK-z)}$ parameter applies only at the end of a multi-word DMA cycle, i.e., when \overline{DMACK} is negated. The device may actively drive the Device Data signals, or may 3-state the device data signals, while \overline{DMACK} is active from the first time that \overline{DIOR} is asserted until \overline{DMACK} is negated as long as $t_{ACC(DIOR)}$ and $t_{h(DIOR)}$ requirements are met.

ATAPI CD-R block encoder/decoder

SAA7391

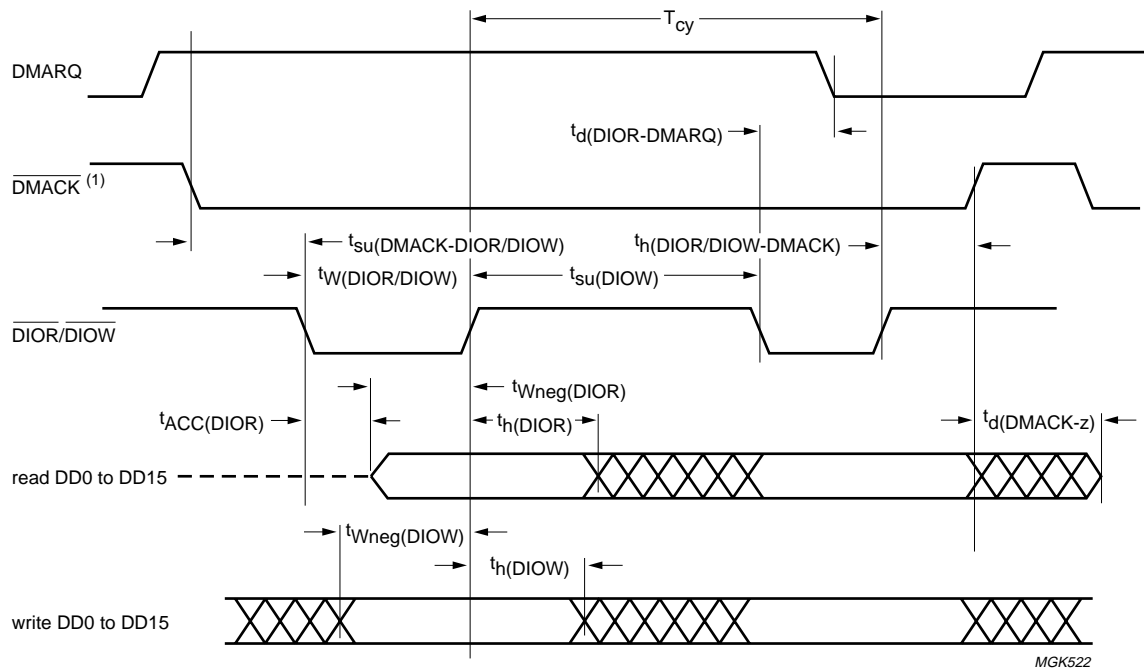

(1) This signal may be negated by the host to suspend the DMA transfer in progress. For multi-word DMA transfers, the device may negate DMARQ within the $t_{d(DIOR-DMARQ)}$ or $t_{d(DIOW-DMARQ)}$ specified time once DMACK is asserted and reassert it again at a later time to resume the DMA operation. Alternatively, if the device is able to continue the transfer of data, the device may leave DMARQ asserted and wait for the host to reassert DMACK.

Fig.17 Multi-word DMA timing.

ATAPI CD-R block encoder/decoder

SAA7391

11.2.3 ULTRA DMA OPERATION AND TIMING

Selection of ultra DMA is similar to multi-word DMA operation. Bits 5, 6 and 7 of the DTCTR register should all be set to logic 1 and data byte counts and data flow selection does not change from ATAPI DMA operation.

The 'ultra_stop' interrupt (IFSTAT bit 4) when enabled by 'ultra_stopen' (IFCTRL bit 4) will interrupt the microcontroller if the host stops a transfer before the required data has been transfer i.e. the data byte count has not reached zero.

A flag, 'crc_error' (IFSTAT bit 0) if asserted in conjunction with the 'dte' interrupt (IFSTAT bit 6) will indicate to the microcontroller that the last transfer of data was corrupt.

No changes of pin direction are required for ultra DMA, but the ATA description changes (see Table 109).

Table 109 Ultra DMA pin changes

ATA PIN NAME	ULTRA DMA READ PIN NAME	ULTRA DMA WRITE PIN NAME	COMMENT
$\overline{\text{IORDY}}$	sender strobe	D_DMARDY (device DMA ready)	D_DMARDY can be used to pause transmission
DMARQ	DMARQ	DMARQ	similar to ATAPI DMA
$\overline{\text{DMACK}}$	$\overline{\text{DMACK}}$	$\overline{\text{DMACK}}$	similar to ATAPI DMA, but also used at the end of transmission for the CRC strobe
$\overline{\text{DIOR}}$	STOP	sender strobe	stop can terminate the data transfer before all bytes have been transferred; this action will generate a microcontroller interrupt
$\overline{\text{DIOW}}$	H_DMARDY (host DMA ready)	STOP	H_DMARDY can be used by to pause transmission

11.2.4 ULTRA DMA READ/WRITE TIMING

This section provides the timing diagrams for the ultra DMA protocol. The timing diagrams are shown in Figs 18 to 27.

The timing information is provided in Table 110.

Table 110 Timing parameter values; see Figs 18 to 27

SYMBOL	PARAMETER	CONDITIONS	MIN.	MAX.	UNIT
T_{cy}	cycle time (from STROBE edge to STROBE edge)	Mode 0	117	–	ns
		Mode 1	77	–	ns
		Mode 2	57	–	ns
$t_{su(D)(RX)}$	data set-up time (at receiver)	Mode 0	15	–	ns
		Mode 1	10	–	ns
		Mode 2	7	–	ns
$t_{h(D)(RX)}$	data hold time (at receiver)	Mode 0	3	–	ns
		Mode 1	3	–	ns
		Mode 2	3	–	ns
$t_{su(DV)}$	data valid set-up time (at sender); time from data bus being valid until STROBE edge	Mode 0	75	–	ns
		Mode 1	48	–	ns
		Mode 2	38	–	ns

ATAPI CD-R block encoder/decoder

SAA7391

SYMBOL	PARAMETER	CONDITIONS	MIN.	MAX.	UNIT
$t_{h(DV)}$	data valid hold time (at sender); time from STROBE edge until data goes invalid	Mode 0	8	–	ns
		Mode 1	8	–	ns
		Mode 2	8	–	ns
t_{li}	limited interlock time; time allowed between an action by one agent and the following action by the other agent	Mode 0	0	150	ns
		Mode 1	0	150	ns
		Mode 2	0	150	ns
$t_{li(min)}$	limited interlock time with minimum	Mode 0	20	150	ns
		Mode 1	20	150	ns
		Mode 2	20	150	ns
t_{ui}	unlimited interlock time	Mode 0	0	–	ns
		Mode 1	0	–	ns
		Mode 2	0	–	ns
$t_{(O-z)(max)}$	maximum time allowed for outputs to 3-state	Mode 0	–	10	ns
		Mode 1	–	10	ns
		Mode 2	–	10	ns
$t_{d(min)}$	minimum delay time for output drivers turning on (from high-impedance)	Mode 0	20	–	ns
		Mode 1	20	–	ns
		Mode 2	20	–	ns
t_{env}	envelope time (all control signal transitions are within the DACKb envelope by this time)	Mode 0	20	70	ns
		Mode 1	20	70	ns
		Mode 2	20	70	ns
$t_{res(STROBE-DMARDY)}$	STROBE-to-DMARDY response time to ensure synchronous pause case (when receiver is pausing)	Mode 0	–	50	ns
		Mode 1	–	30	ns
		Mode 2	–	20	ns
$t_{(READY-STROBE)}$	READY-to-final-STROBE time (this long after DMARDYb de-assertion, no more STROBE edges may be sent)	Mode 0	–	75	ns
		Mode 1	–	60	ns
		Mode 2	–	50	ns
$t_{(READY-PAUSE)}$	READY-to-pause time: time until a receiver may assume that the sender has paused after de-asserting DMARDYb	Mode 0	160	–	ns
		Mode 1	125	–	ns
		Mode 2	100	–	ns
t_{pu}	pull-up time before allowing \overline{IORDY} to go high-impedance	Mode 0	–	20	ns
		Mode 1	–	20	ns
		Mode 2	–	20	ns
$t_{(IORDY)(max)}$	maximum time driver must wait before driving \overline{IORDY}	Mode 0	0	–	ns
		Mode 1	0	–	ns
		Mode 2	0	–	ns
$t_{su(ass/deass)}$	set-up time before assertion and de-assertion of DACKb	Mode 0	20	–	ns
		Mode 1	20	–	ns
		Mode 2	20	–	ns

ATAPI CD-R block encoder/decoder

SAA7391

SYMBOL	PARAMETER	CONDITIONS	MIN.	MAX.	UNIT
$t_{h(ass/deass)}$	hold time before assertion and de-assertion of DACKb	Mode 0	20	–	ns
		Mode 1	20	–	ns
		Mode 2	20	–	ns
$t_{ss(STROBE-STOP)}$	time from STROBE edge to negation of DMARQ or assertion of STOP	Mode 0	50	–	ns
		Mode 1	50	–	ns
		Mode 2	50	–	ns

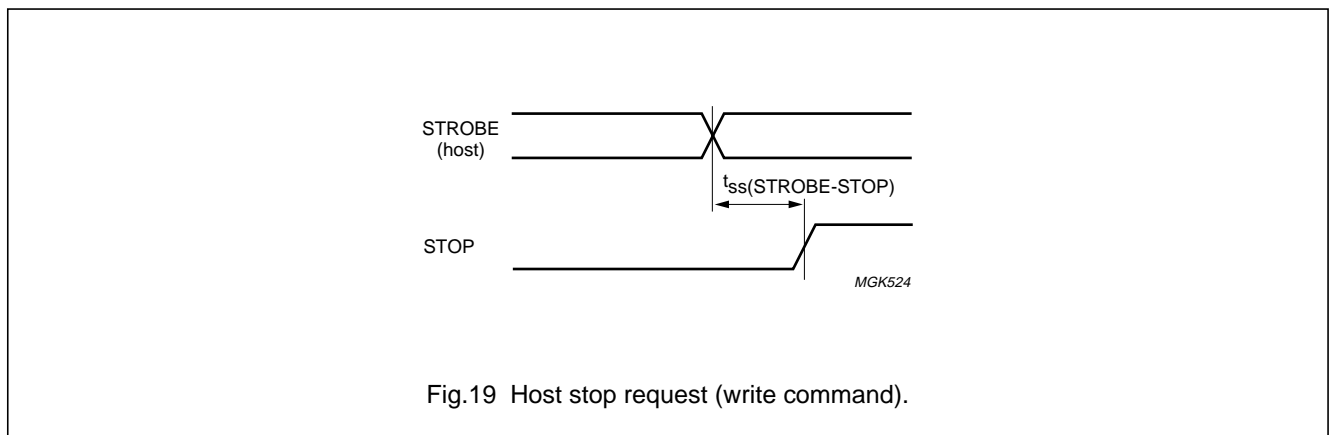
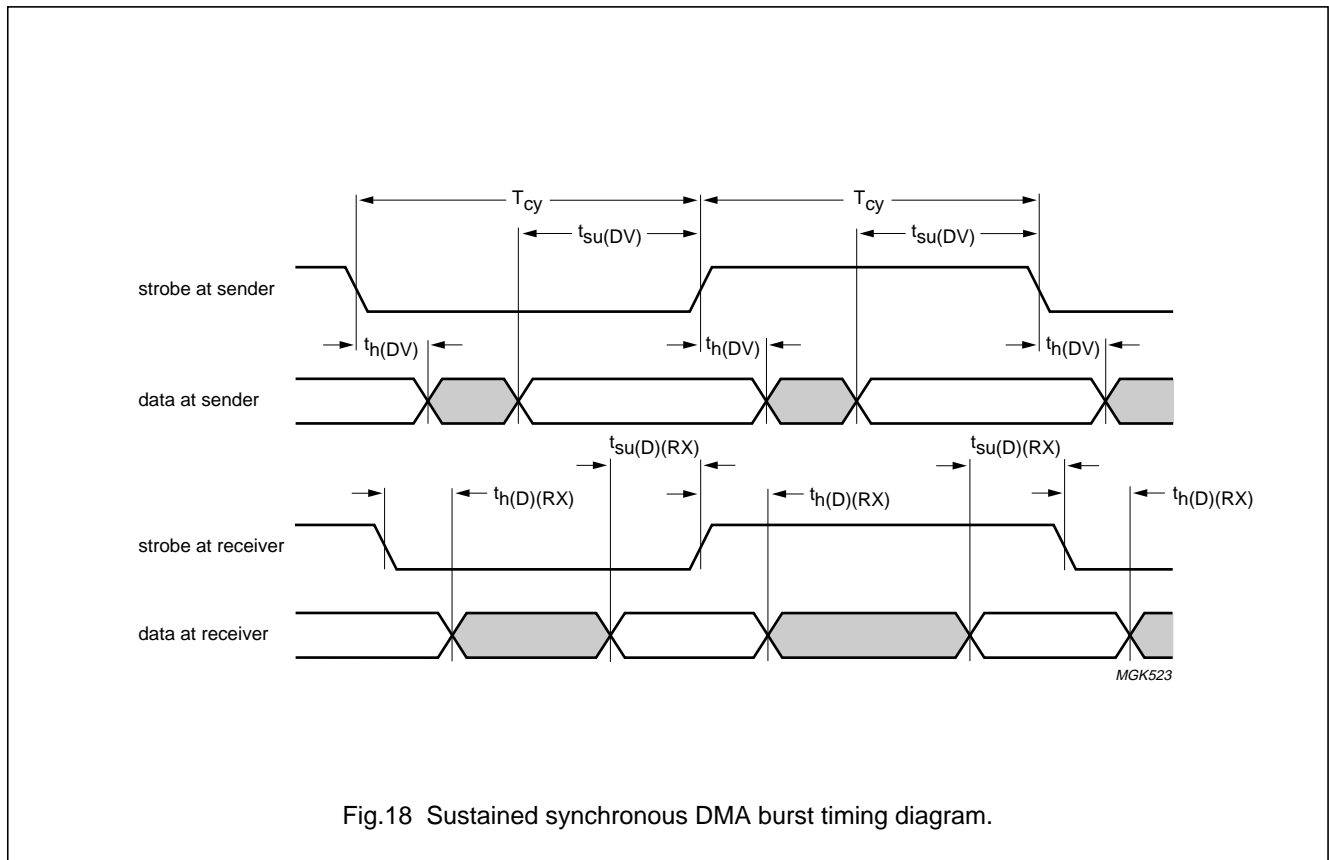

ATAPI CD-R block encoder/decoder

SAA7391

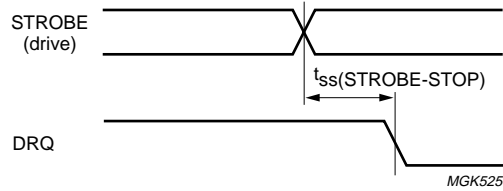

Fig.20 Drive stop request (read command).

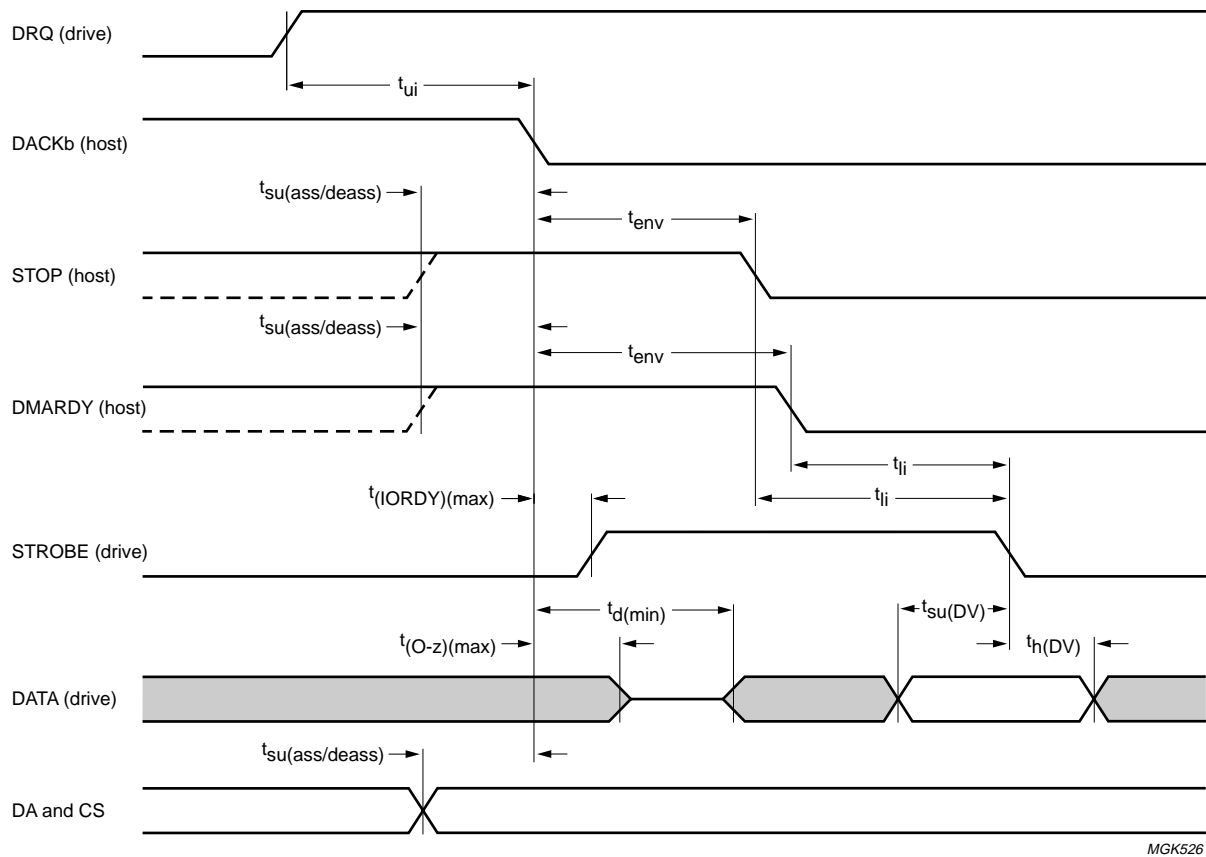

Fig.21 Drive initiating a DMA burst for a write command.

ATAPI CD-R block encoder/decoder

SAA7391

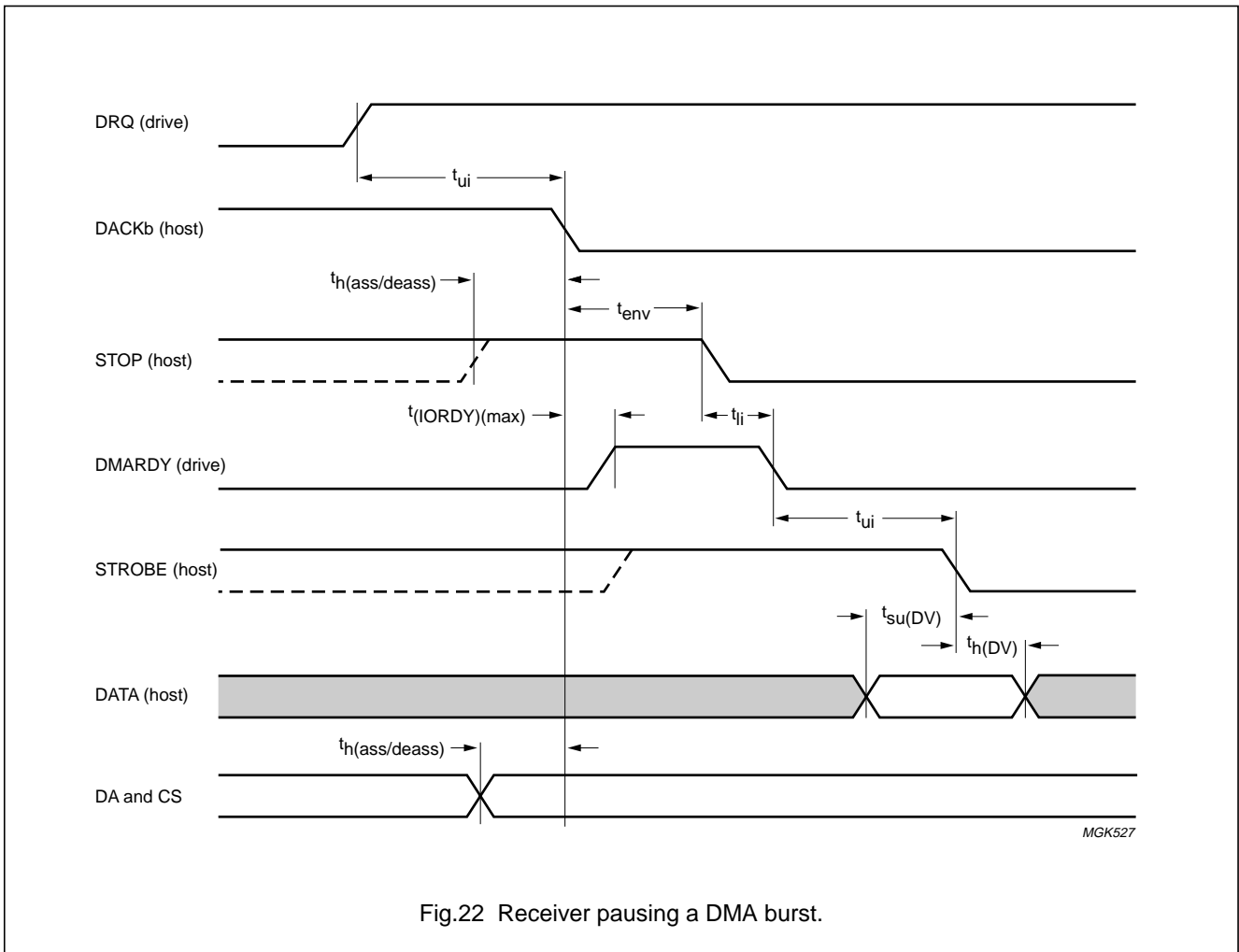

Fig.22 Receiver pausing a DMA burst.

ATAPI CD-R block encoder/decoder

SAA7391

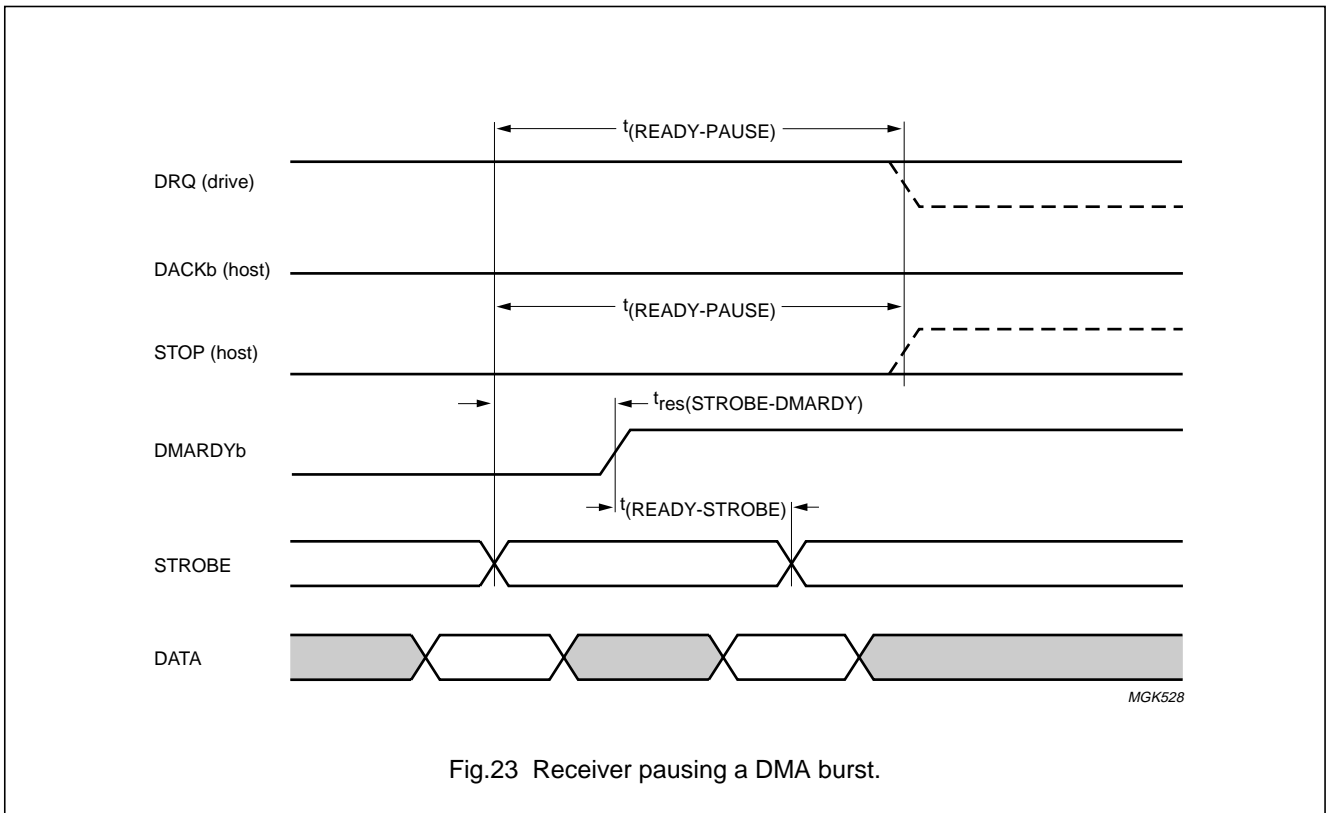

Fig.23 Receiver pausing a DMA burst.

ATAPI CD-R block encoder/decoder

SAA7391

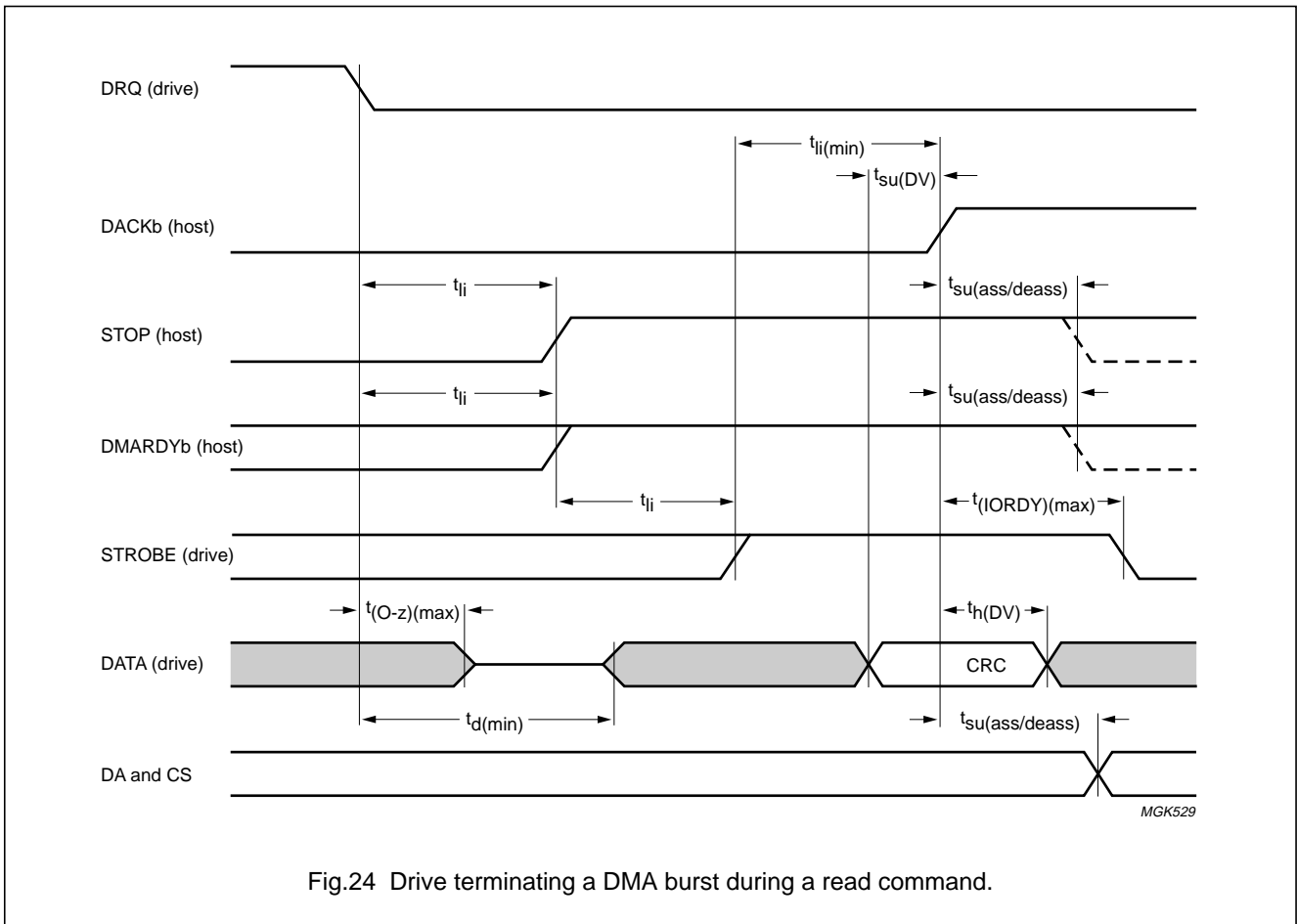

Fig.24 Drive terminating a DMA burst during a read command.

ATAPI CD-R block encoder/decoder

SAA7391

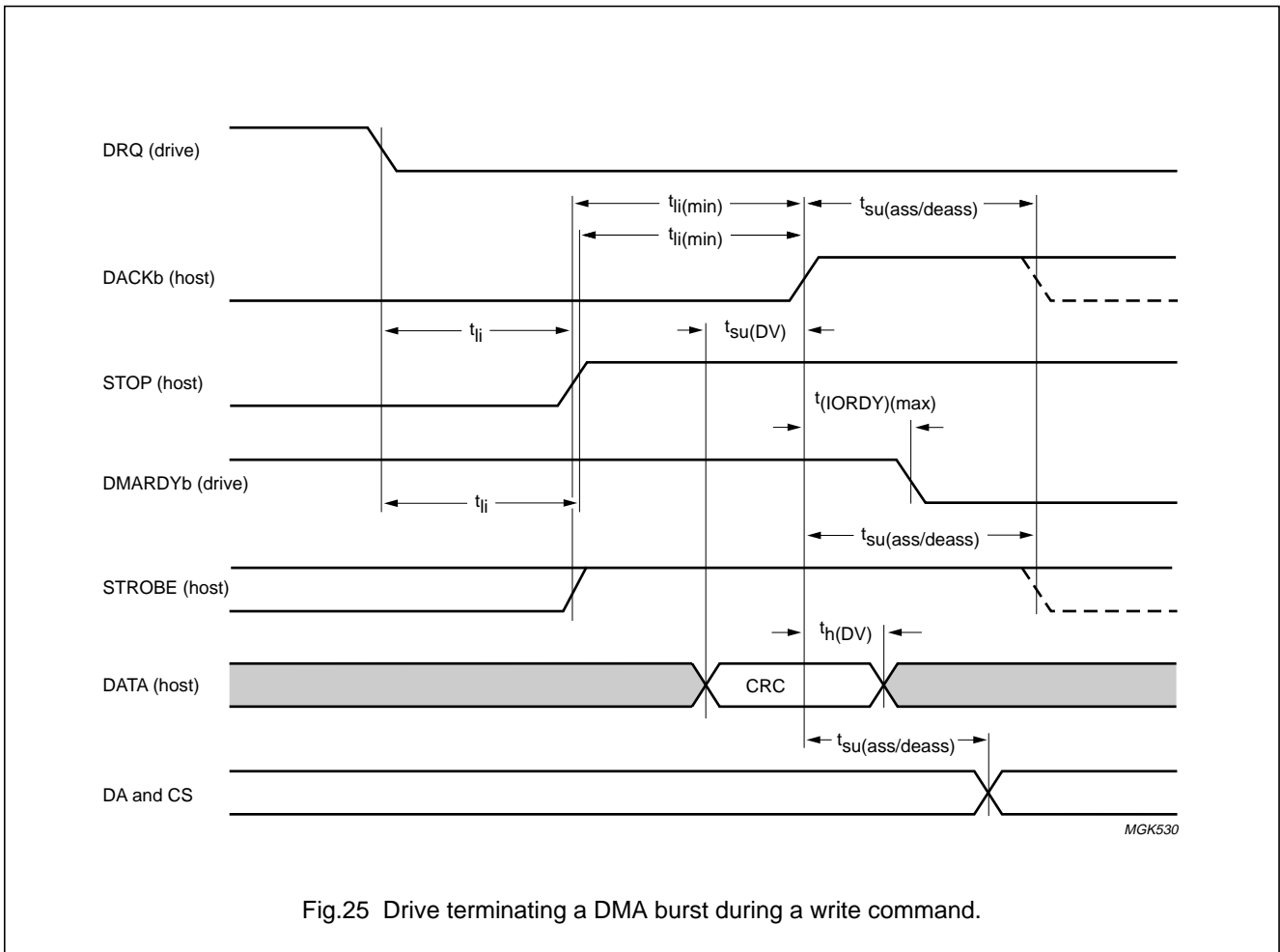

Fig.25 Drive terminating a DMA burst during a write command.

ATAPI CD-R block encoder/decoder

SAA7391

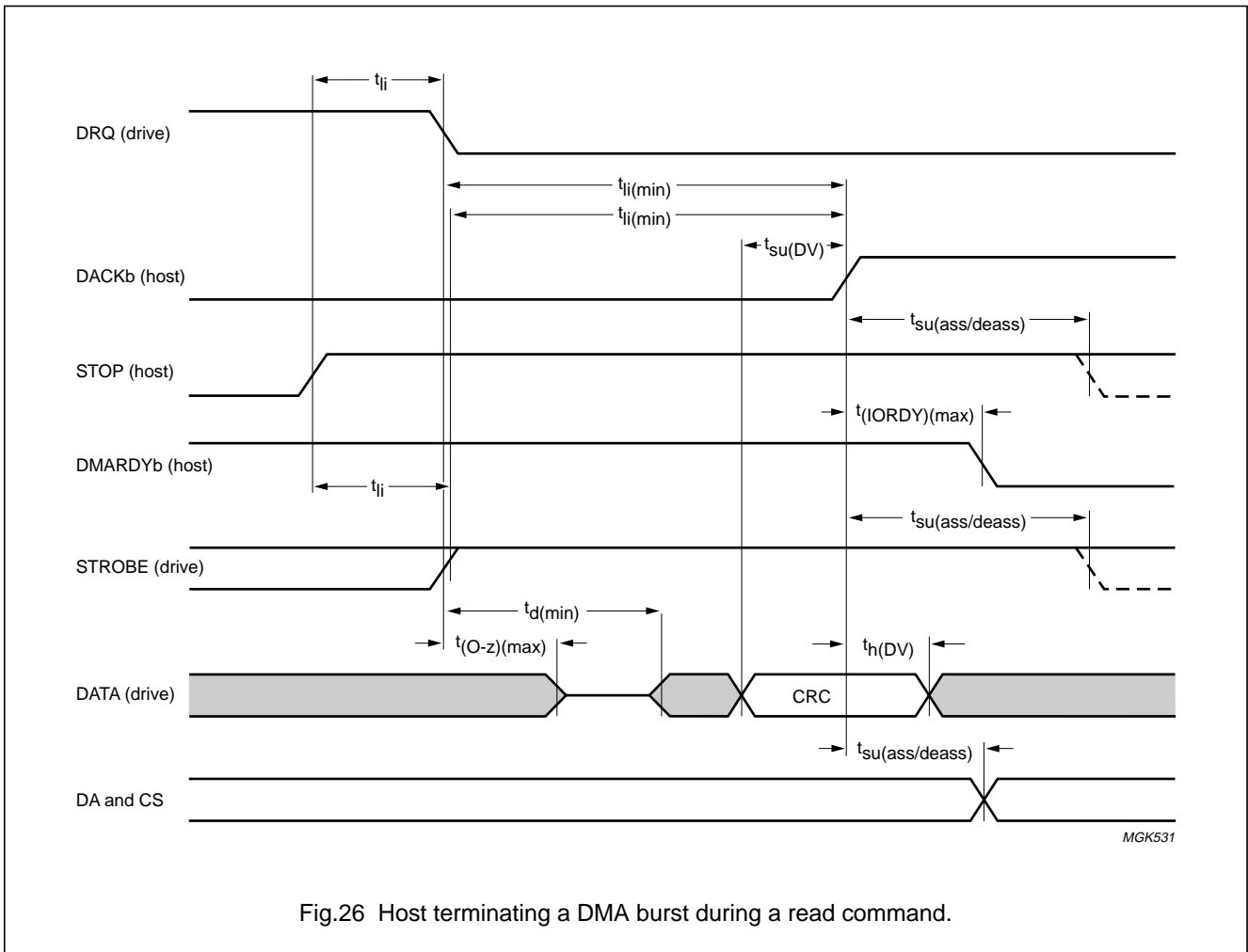

Fig.26 Host terminating a DMA burst during a read command.

ATAPI CD-R block encoder/decoder

SAA7391

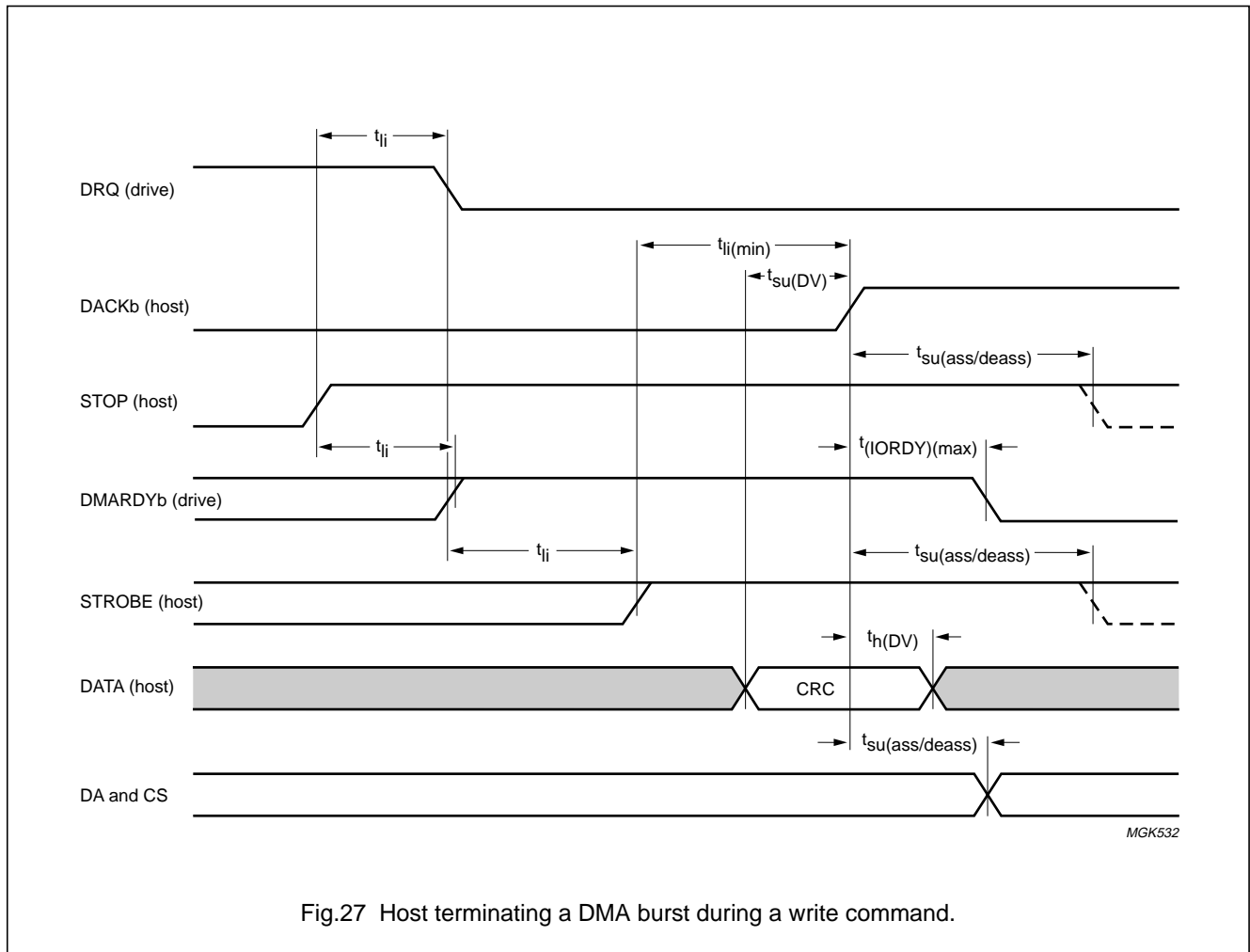

Fig.27 Host terminating a DMA burst during a write command.

11.3 Sub-CPU interface timing

Table 111 Timing parameter values for Figs 28 and 29

SYMBOL	PARAMETER	MIN.	MAX.	UNIT
t_{AVLL}	address valid to ALE LOW	10	–	ns
t_{RLDV}	\overline{RD} LOW to valid data in	–	$7t_{CLCL} + 20^{(1)}$	ns
$t_{W(ALE)}$	ALE pulse width	35	–	ns
$t_{h(A)}$	address hold time	10	–	ns
t_{DVWL}	DATA valid before \overline{WR} LOW	0	–	ns

Note

- t_{CLCL} = the SAA7391 system clock period.

ATAPI CD-R block encoder/decoder

SAA7391

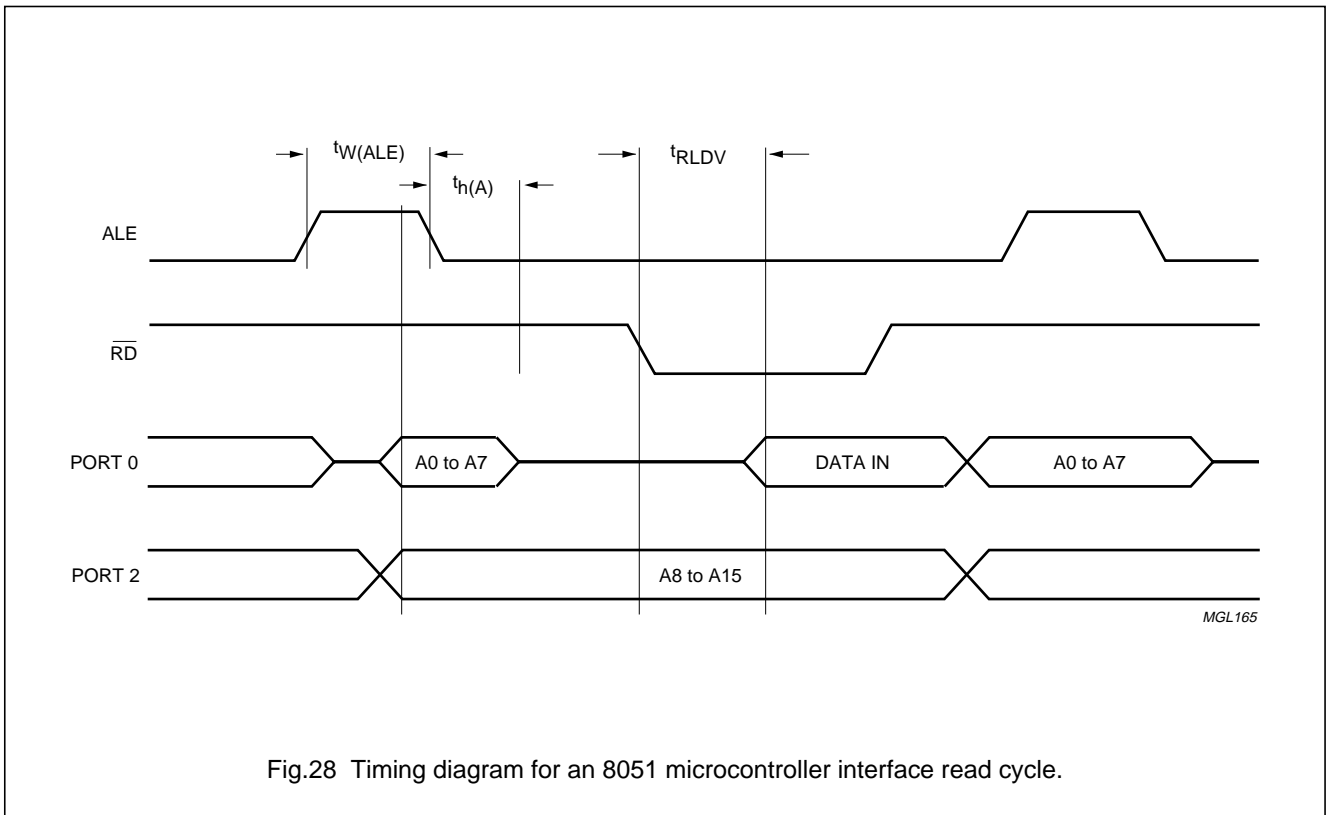

Fig.28 Timing diagram for an 8051 microcontroller interface read cycle.

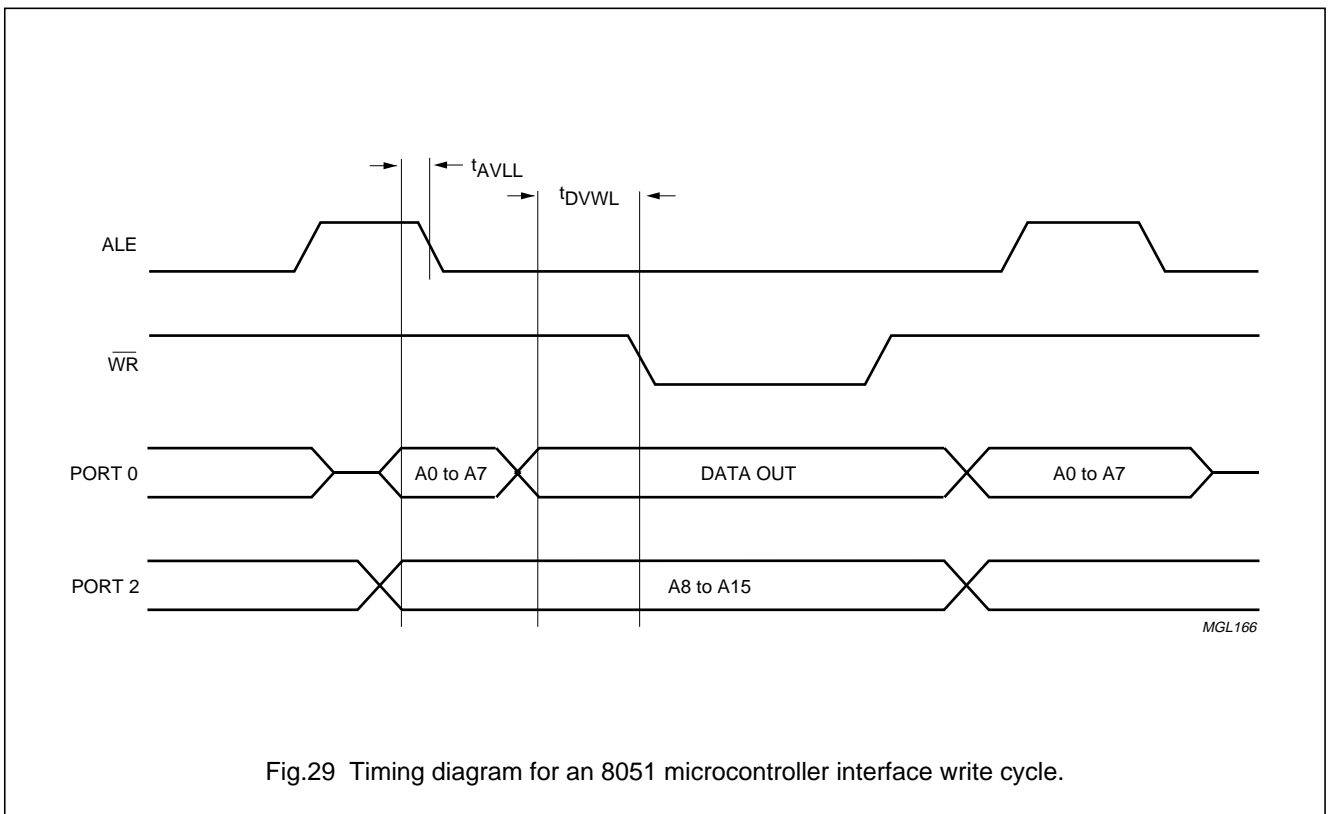
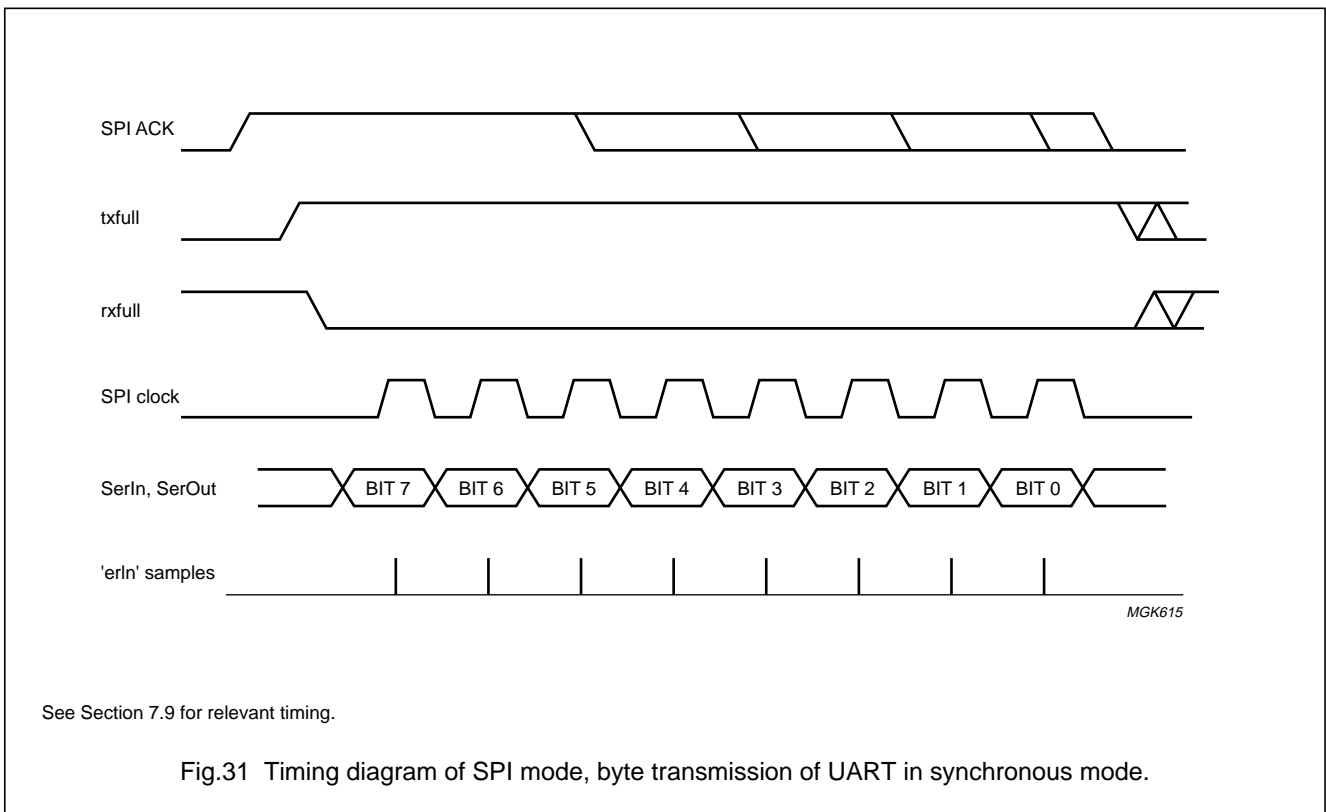
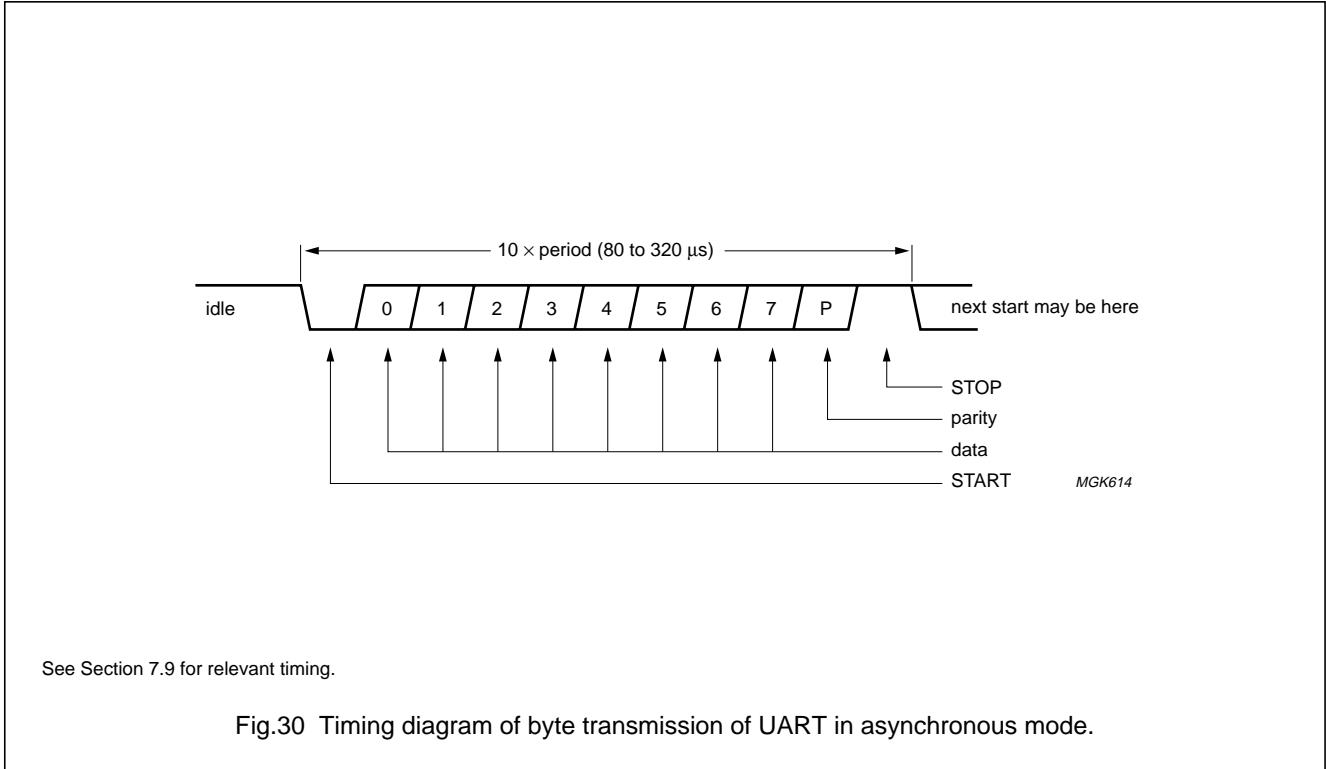

Fig.29 Timing diagram for an 8051 microcontroller interface write cycle.

ATAPI CD-R block encoder/decoder

SAA7391

11.4 UART timing



ATAPI CD-R block encoder/decoder

SAA7391

12 APPENDIX A

Table 112 The SAA7391 register map

ADDRESS	NAME	ACCESS	BLOCK	NUMBER OF BITS	COMMENT	ELM 'NEAR EQUIVALENT' REGISTER	CHAUCER 'NEAR EQUIVALENT' REGISTER
FF00H	HEAD0	R	drive	8	see Table 20	HEAD0	–
FF01H	HEAD1	R	drive	8		HEAD1	–
FF02H	HEAD2	R	–	8		HEAD2	–
FF03H	HEAD3	R	–	8		HEAD3	–
FF04H	SUBHEAD0	R	–	8		SHEAD0	–
FF05H	SUBHEAD1	R	–	8		SHEAD1	–
FF06H	SUBHEAD2	R	–	8		SHEAD2	–
FF07H	SUBHEAD3	R	–	8		SHEAD3	–
FF08H	STAT0	R	–	8		STAT0	–
FF09H	STAT1	R	–	8		STAT1	–
FF0AH	STAT2	R	–	8		STAT2	–
FF0BH	STAT3	R	–	8		STAT3	–
FF0CH	STAT4	R	–	8		STAT3	–
FF0DH	CTRL0	W	–	8		see Table 16	CTRL0
FF0EH	CTRL1	W	–	8	CTRL1		–
FF0FH	CTRL2	W	–	8	CTRL1		–
FF10H	IFCONFIG	W	drive	8	see Table 12	IFCONFIG	FECTRL
FF11H	C1BLERCNT	R	–	8	see Table 97	–	–
FF12H	C2BLERCNT	R	–	8		–	–
FF13H	SUBMODETX	W	–	8	see Table 30	–	–
FF14H	MMAUD	W	–	8	see Table 35	–	–
FF15H	MCK_CON	W	–	8		–	–
FF16H	MMCTRL	W	–	8		–	–
FF17H	SUBMODERX	W	–	8	see Table 32	–	–
FF18H	SUBPAGE1-H	W	–	16	see Table 89	–	PAGEREG
FF19H	SUBPAGE1-L	W	–			–	PAGEREG
FF1AH	SUBPAGE2-H	W	–	16		–	–
FF1BH	SUBPAGE2-L	W	–			–	–

ATAPI CD-R block encoder/decoder

SAA7391

ADDRESS	NAME	ACCESS	BLOCK	NUMBER OF BITS	COMMENT	ELM 'NEAR EQUIVALENT' REGISTER	CHAUCER 'NEAR EQUIVALENT' REGISTER	
FF1CH	SUBSEG1-H	W	-	16	see Table 90	-	MICFRM#	
FF1DH	SUBSEG1-L	W	-			-	MICFRM#	
FF1EH	-	-	-	-	-	-	-	
FF1FH	-	-	-	-	-	-	-	
FF20H	DRIVECURSEG-H	RW	-	16	see Table 14	-	FEFRM#	
FF21H	DRIVECURSEG-L	RW	-			-	FEFRM#	
FF22H	DRIVEPREVSEG-H	RW	-	16		-	LASTCMPFM/EC CFRM	
FF23H	DRIVEPREVSEG-L	RW	-			-	FEFRMOFF	
FF24H	DRIVEOFFSET-H	RW	-	16		-	FEFRMOFF	
FF25H	DRIVEOFFSET-L	RW	-			-	-	
FF26H	DRIVENEXTSEG-H	RW	-	16	see Table 14	-	-	
FF27H	DRIVENEXTSEG-L	RW	-			-	-	
FF28H	AUXSEGMENT-H	RW	-	16	see Table 29	-	-	
FF29H	AUXSEGMENT-L	RW	-			-	-	
FF2AH	SUBPOINTR-H	RW	-	16	see Table 34	-	-	
FF2BH	SUBPOINTR-L	RW	-			-	-	
FF2CH	SUBBASEPOINTR-H	RW	-			16	-	-
FF2DH	SUBBASEPOINTR-L	RW	-				-	-
FF2EH	SUBPOINTW-H	RW	-	16		SUB-H	-	
FF2FH	SUBPOINTW-L	RW	-			-	SUB-L	-
FF30H	SUBBASEPOINTW-H	RW	-	16		SUB-H	-	
FF31H	SUBBASEPOINTW-L	RW	-			-	SUB-L	-
FF32H	CDDA-H	RW	-	16	see Table 35	-	-	
FF33H	CDDA-L	RW	-			-	-	
FF34H	DAOFFSET-H	RW	-	16		-	-	
FF35H	DAOFFSET-L	RW	-			-	-	

ATAPI CD-R block encoder/decoder

SAA7391

ADDRESS	NAME	ACCESS	BLOCK	NUMBER OF BITS	COMMENT	ELM 'NEAR EQUIVALENT' REGISTER	CHAUCER 'NEAR EQUIVALENT' REGISTER	
FF36H	COPYFROMOFFSET-H	RW	-		see Table 42		-	
FF37H	COPYFROMOFFSET-L	RW	-			-	-	
FF38H	COPYTOOFFSET-H	RW	-	16		-	-	
FF39H	COPYTOOFFSET-L	RW	-			-	-	
FF3AH	COPYFROMSEG-H	RW	-	16		-	-	
FF3BH	COPYFROMSEG-L	RW	-			-	-	
FF3CH	COPYTOSEG-H	RW	-			-	-	
FF3DH	COPYTOSEG-L	RW	-			-	-	
FF3EH	FROM2OFFSET-H	RW	-	16		-	-	
FF3FH	FROM2OFFSET-L	RW	-			-	-	
FF40H	TO2OFFSET-H	RW	-	16		-	-	
FF41H	TO2OFFSET-L	RW	-			-	-	
FF42H	HOSTBYTEOFFSET-H	RW	-	16		see Table 85	DAC	-
FF43H	HOSTBYTEOFFSET-L	RW	-				DAC	-
FF44H	HOSTCURSEG-H	RW	-	16	DAC		SCSICFRM	
FF45H	HOSTCURSEG-L	RW	-		DAC		SCSICFRM	
FF46H	-	-	-	-	-	-	-	
FF47H	-	-	-	-	-	-	-	
FF48H	-	-	-	-	-	-	-	
FF49H	-	-	-	-	-	-	-	
FF4AH	SPI_RX_OFF-H	RW	-	16	see Table 93	-	-	
FF4BH	SPI_RX_OFF-L	RW	-			-	-	
FF4CH	SPI_TX_OFF-H	RW	-	16		-	-	
FF4DH	SPI_TX_OFF-L	RW	-			-	-	
FF4EH	-	-	-	-	-	-	-	
FF4FH	-	-	-	-	-	-	-	

ATAPI CD-R block encoder/decoder

SAA7391

ADDRESS	NAME	ACCESS	BLOCK	NUMBER OF BITS	COMMENT	ELM 'NEAR EQUIVALENT' REGISTER	CHAUCER 'NEAR EQUIVALENT' REGISTER
FF50H	HOSTSUBBLKOFFSET2-H	RW	-	16	see Table 85	-	-
FF51H	HOSTSUBBLKOFFSET2-L	RW	-				
FF52H	HOSTSUBBLKCOUNT2-H	RW	-	16		-	-
FF53H	HOSTSUBBLKCOUNT2-L	RW	-				
FF54H	HOSTNEXTSEG-H	RW	-	16		-	SCSISFRM
FF55H	HOSTNEXTSEG-L	RW	-			-	SCSISFRM
FF56H	HOSTRELOADFLAGS	RW	-	16		-	-
FF57H	HOSTNEXTSEGCOUNT	RW	-			-	-
FF58H	HOSTSUBBLKOFFSET0-H	RW	-	16		-	-
FF59H	hostsubblkoffset0-L	RW	-			-	-
FF5AH	HOSTSUBBLKCOUNT0-H	RW	-	16		-	-
FF5BH	HOSTSUBBLKCOUNT0-L	RW	-			-	-
FF5CH	HOSTSUBBLKOFFSET1-H	RW	-	16		-	-
FF5DH	HOSTSUBBLKOFFSET1-L	RW	-			-	-
FF5EH	HOSTSUBBLKCOUNT1-H	RW	-	16	-	-	
FF5FH	HOSTSUBBLKCOUNT1-L	RW	-		-	-	
FF60H	DRIVECURCOUNT	RW	-	8	see Table 14	-	-
FF61H	DRIVENEXTCOUNT	RW	-	8		-	-
FF62H	COPYCOUNT-H	RW	-	8	see Table 42	-	-
FF63H	COPYCOUNT-L	RW	-	8		-	-
FF64H	HOSTBYTECOUNT-H	RW	-	8	see Table 85	-	-
FF65H	HOSTBYTECOUNT-L	RW	-	8		-	-
FF66H	HOSTCURSEGCNT	RW	-	8		-	-
FF67H	COPYCONTROL	RW	-	8	see Table 42	-	-
FF68H	HOSTRELSEG-H	RW	-	16	see Table 85	-	-
FF69H	HOSTRELSEG-L	RW	-			-	-
FF6AH	DRAM_CONFIG	W	-	8	see Table 90	MEMS	DRAMSEL
FF6BH	AUX_FORM_SCAN	RW	-	8	see Table 85	-	-
FF6CH	-	-	-	-	-	-	-
FF6DH	-	-	-	-	-	-	-

ATAPI CD-R block encoder/decoder

SAA7391

ADDRESS	NAME	ACCESS	BLOCK	NUMBER OF BITS	COMMENT	ELM 'NEAR EQUIVALENT' REGISTER	CHAUCER 'NEAR EQUIVALENT' REGISTER
FF6EH	-	-	-	-	-	-	-
FF6FH	TEMP_DATA	RW	-	8	holding register; see Section 7.6	-	-
FF70H	IECTRL	W	-	8	see Table 35	-	-
FF71H	IECCAT	W	-	8		-	-
FF72H	-	-	-	-	-	-	-
FF73H	CONF_8051	W	-	8	see Table 98	-	-
FF74H	UART_PRESCALER	RW	-	8	see Table 93	-	-
FF75H	UART_DMA_CTRL	RW	-	8		-	BRGSEL
FF76H	UARTCOM	W	-	8		-	-
FF77H	RXDATA/TXDATA	RW	-	8		-	SERCOM
FF78H	UARTINTSTAT/RESET	RW	-	8		-	-
FF79H	UARTINTENABLE	W	-	8		-	-
FF7AH	INT1STAT/RESET	RW	-	8	see Tables 45 and 46	-	-
FF7BH	INT1ENABLE	W	-	8	see Table 47	-	-
FF7CH	INT2STAT/RESET	RW	-	8	see Tables 48 and 49	-	-
FF7DH	INT2ENABLE	W	-	8	see Table 50	-	-
FF7EH	UARTSTAT	R	-	8	see Table 93	-	-
FF7FH	UARTAUXSTAT	R	-	8		-	-

ATAPI CD-R block encoder/decoder

SAA7391

ADDRESS	NAME	ACCESS	BLOCK	NUMBER OF BITS	COMMENT	ELM 'NEAR EQUIVALENT' REGISTER	CHAUCER 'NEAR EQUIVALENT' REGISTER
FF80H	ADATA	RW	-	8	see Table 56	ADATA	-
FF81H	IFCTRL	RW	-	8		IFCTRL	-
FF82H	DBCL	RW	-	8		DBCL	-
FF83H	DBCH	RW	-	8		DBCH	-
FF84H	DTRG	W	-	8		DTRG	-
FF85H	DTACK	W	-	8		DTACK	-
FF86H	$\overline{\text{RESET}}$	W	-	8		$\overline{\text{RESET}}$	-
FF87H	ASTAT	RW	-	8		ASTAT	-
FF88H	ITRG	W	-	8		ITRG	-
FF89H	ADRADR	W	-	8		ADRADR	-
FF8AH	ASAMT	RW	-	8		ASAMT	-
FF8BH	DTCTR	RW	-	8		DTCTR	-
FF8CH	ADRSEL	RW	-	8		ADRSEL	-
FF8DH	AINTR	RW	-	8		AINTR	-
FF8EH	AERR	RW	-	8		AERR	-
FF8FH	ACMD	R	-	8		ACMD	-
FF90H	ADCTR	R	-	8		ADCTR	-
FF91H	AFEAT	R	-	8		AFEAT	-
FF92H	IFSTAT	RW	-	8		IFSTAT	-
FF93H	APCMD	R	-	8		APCMD	-
FF94H	HICONF0	RW	-	8		-	-
FF95H	HICONF1	RW	-	8		-	-
FF96H	HISEQ	RW	-	8		-	-
FF97H	SHSTAT	RW	-	8		-	-
FF98H	SHERR	RW	-	8		-	-
FF99H	HIDEV	RW	-	8		-	-
FF9AH	HISTAT	R	-	8	-	-	
FF9BH	3 unused address locations						
FF9CH							
FF9DH							

ATAPI CD-R block encoder/decoder

SAA7391

ADDRESS	NAME	ACCESS	BLOCK	NUMBER OF BITS	COMMENT	ELM 'NEAR EQUIVALENT' REGISTER	CHAUCER 'NEAR EQUIVALENT' REGISTER
FF9EH	MULTI_CON	-	-	8	see Table 100	-	-
FF9FH	CLK_CON	-	-			-	CLKSEL
FFA0H	TRANSFERCOUNT (7 to 0)	RW	-	32	see Table 56	-	-
FFA1H	TRANSFERCOUNT (15 to 8)	RW	-			-	-
FFA2H	TRANSFERCOUNT (23 to 16)	RW	-			-	-
FFA3H	TRANSFERCOUNT (31 to 24)	RW	-			-	-
FFA4H	PACKETSIZE_STORE(L)	RW	-	16		-	-
FFA5H	PACKETSIZE_STORE(H)	RW	-			-	-
FFA6H	SEQUENCER_STATUS	R	-	8		-	-
FFA7H	25 unused address locations						
FFBFH							
FFC0H	32 generic addresses in 3-state locations						
FFDFH							
FFE0H	32 3-state address locations						
FFFFH							

ATAPI CD-R block encoder/decoder

SAA7391

13 APPLICATION INFORMATION

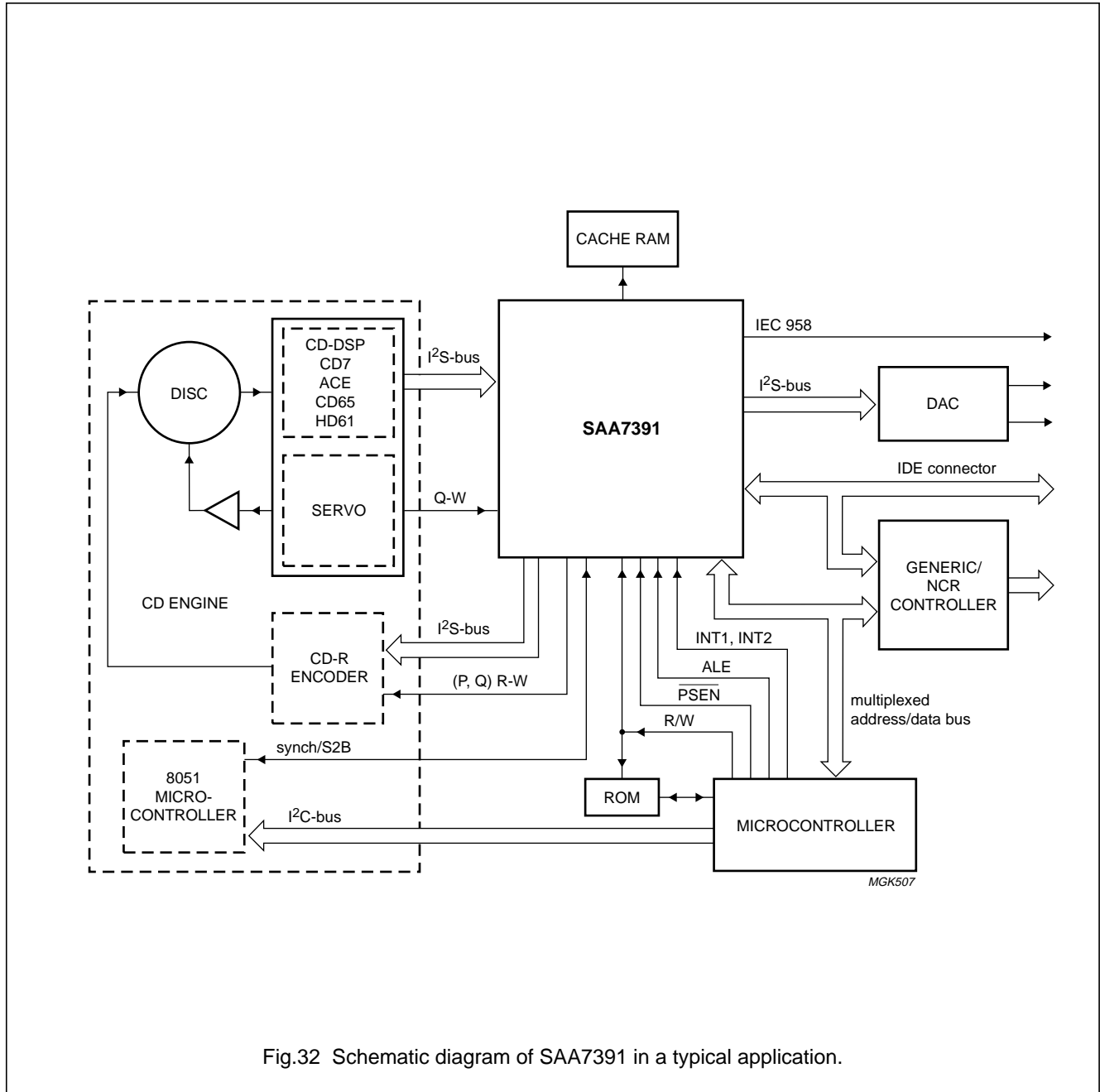

ATAPI CD-R block encoder/decoder

SAA7391

14 PACKAGE OUTLINE

LQFP144: plastic low profile quad flat package; 144 leads; body 20 x 20 x 1.4 mm

SOT486-1

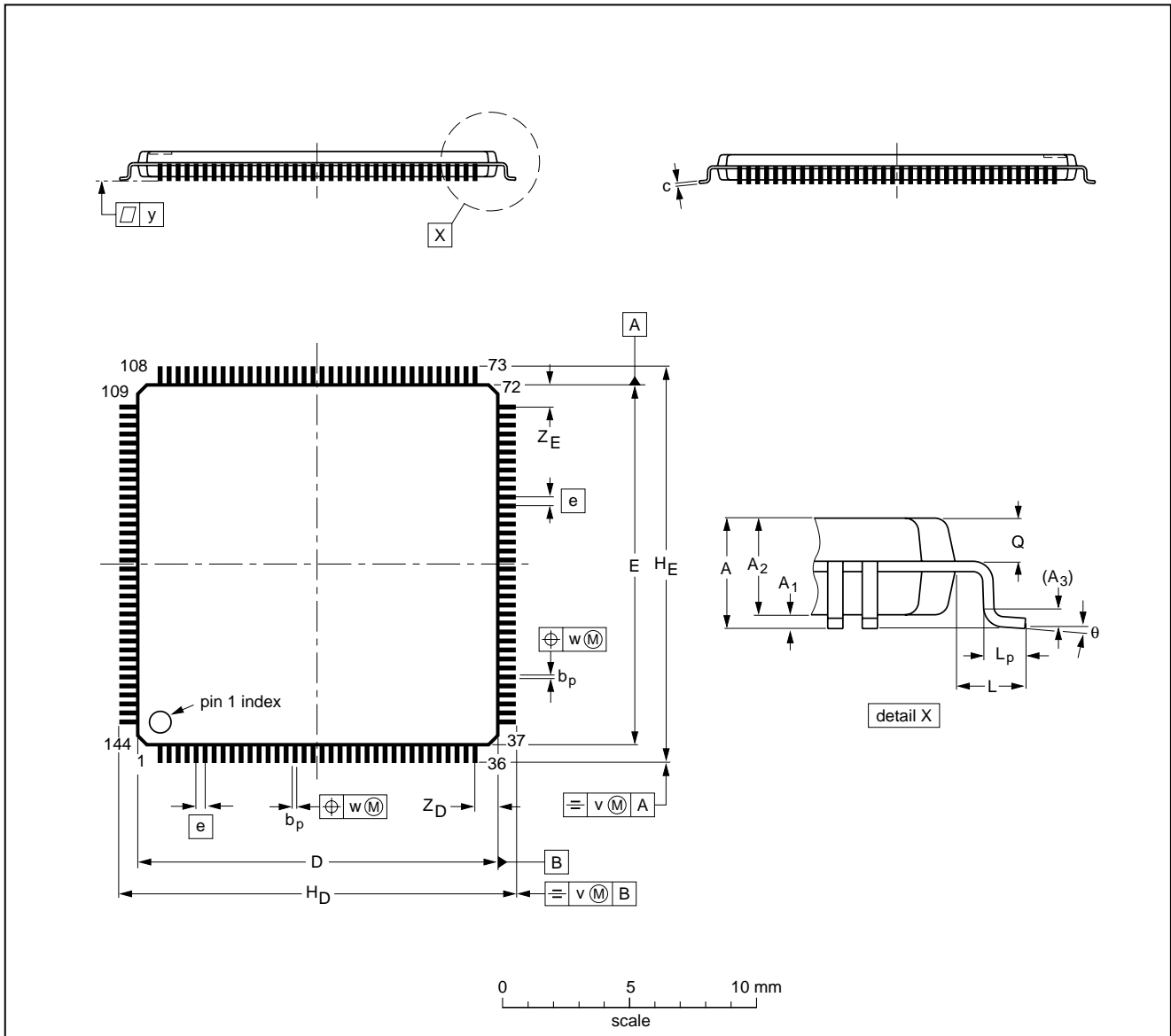

DIMENSIONS (mm are the original dimensions)

UNIT	A max.	A ₁	A ₂	A ₃	b _p	c	D ⁽¹⁾	E ⁽¹⁾	e	H _D	H _E	L	L _p	Q	v	w	y	Z _D ⁽¹⁾	Z _E ⁽¹⁾	θ
mm	1.6	0.15 0.05	1.45 1.35	0.25	0.27 0.17	0.20 0.09	20.1 19.9	20.1 19.9	0.50	22.15 21.85	22.15 21.85	1.0	0.75 0.45	0.69 0.59	0.2	0.1	0.1	1.40 1.10	1.40 1.10	7° 0°

Note

1. Plastic or metal protrusions of 0.25 mm maximum per side are not included.

OUTLINE VERSION	REFERENCES				EUROPEAN PROJECTION	ISSUE DATE
	IEC	JEDEC	EIAJ			
SOT486-1						97-07-02

ATAPI CD-R block encoder/decoder

SAA7391

15 SOLDERING

15.1 Introduction

There is no soldering method that is ideal for all IC packages. Wave soldering is often preferred when through-hole and surface mounted components are mixed on one printed-circuit board. However, wave soldering is not always suitable for surface mounted ICs, or for printed-circuits with high population densities. In these situations reflow soldering is often used.

This text gives a very brief insight to a complex technology. A more in-depth account of soldering ICs can be found in our *"IC Package Databook"* (order code 9398 652 90011).

15.2 Reflow soldering

Reflow soldering techniques are suitable for all LQFP packages.

Reflow soldering requires solder paste (a suspension of fine solder particles, flux and binding agent) to be applied to the printed-circuit board by screen printing, stencilling or pressure-syringe dispensing before package placement.

Several techniques exist for reflowing; for example, thermal conduction by heated belt. Dwell times vary between 50 and 300 seconds depending on heating method. Typical reflow temperatures range from 215 to 250 °C.

Preheating is necessary to dry the paste and evaporate the binding agent. Preheating duration: 45 minutes at 45 °C.

15.3 Wave soldering

Wave soldering is **not** recommended for LQFP packages. This is because of the likelihood of solder bridging due to closely-spaced leads and the possibility of incomplete solder penetration in multi-lead devices.

If wave soldering cannot be avoided, the following conditions must be observed:

- **A double-wave (a turbulent wave with high upward pressure followed by a smooth laminar wave) soldering technique should be used.**
- **The footprint must be at an angle of 45° to the board direction and must incorporate solder thieves downstream and at the side corners.**

Even with these conditions, do not consider wave soldering LQFP packages LQFP48 (SOT313-2), LQFP64 (SOT314-2) or LQFP80 (SOT315-1).

During placement and before soldering, the package must be fixed with a droplet of adhesive. The adhesive can be applied by screen printing, pin transfer or syringe dispensing. The package can be soldered after the adhesive is cured.

Maximum permissible solder temperature is 260 °C, and maximum duration of package immersion in solder is 10 seconds, if cooled to less than 150 °C within 6 seconds. Typical dwell time is 4 seconds at 250 °C.

A mildly-activated flux will eliminate the need for removal of corrosive residues in most applications.

15.4 Repairing soldered joints

Fix the component by first soldering two diagonally-opposite end leads. Use only a low voltage soldering iron (less than 24 V) applied to the flat part of the lead. Contact time must be limited to 10 seconds at up to 300 °C. When using a dedicated tool, all other leads can be soldered in one operation within 2 to 5 seconds between 270 and 320 °C.

ATAPI CD-R block encoder/decoder

SAA7391

16 DEFINITIONS

Data sheet status	
Objective specification	This data sheet contains target or goal specifications for product development.
Preliminary specification	This data sheet contains preliminary data; supplementary data may be published later.
Product specification	This data sheet contains final product specifications.
Limiting values	
Limiting values given are in accordance with the Absolute Maximum Rating System (IEC 134). Stress above one or more of the limiting values may cause permanent damage to the device. These are stress ratings only and operation of the device at these or at any other conditions above those given in the Characteristics sections of the specification is not implied. Exposure to limiting values for extended periods may affect device reliability.	
Application information	
Where application information is given, it is advisory and does not form part of the specification.	

17 LIFE SUPPORT APPLICATIONS

These products are not designed for use in life support appliances, devices, or systems where malfunction of these products can reasonably be expected to result in personal injury. Philips customers using or selling these products for use in such applications do so at their own risk and agree to fully indemnify Philips for any damages resulting from such improper use or sale.

ATAPI CD-R block encoder/decoder

SAA7391

NOTES

ATAPI CD-R block encoder/decoder

SAA7391

NOTES

Philips Semiconductors – a worldwide company

Argentina: see South America

Australia: 34 Waterloo Road, NORTH RYDE, NSW 2113,
Tel. +61 2 9805 4455, Fax. +61 2 9805 4466

Austria: Computerstr. 6, A-1101 WIEN, P.O. Box 213, Tel. +43 160 1010,
Fax. +43 160 101 1210

Belarus: Hotel Minsk Business Center, Bld. 3, r. 1211, Volodarski Str. 6,
220050 MINSK, Tel. +375 172 200 733, Fax. +375 172 200 773

Belgium: see The Netherlands

Brazil: see South America

Bulgaria: Philips Bulgaria Ltd., Energoproject, 15th floor,
51 James Bourchier Blvd., 1407 SOFIA,
Tel. +359 2 689 211, Fax. +359 2 689 102

Canada: PHILIPS SEMICONDUCTORS/COMPONENTS,
Tel. +1 800 234 7381

China/Hong Kong: 501 Hong Kong Industrial Technology Centre,
72 Tat Chee Avenue, Kowloon Tong, HONG KONG,
Tel. +852 2319 7888, Fax. +852 2319 7700

Colombia: see South America

Czech Republic: see Austria

Denmark: Prags Boulevard 80, PB 1919, DK-2300 COPENHAGEN S,
Tel. +45 32 88 2636, Fax. +45 31 57 0044

Finland: Sinikalliontie 3, FIN-02630 ESPOO,
Tel. +358 9 615800, Fax. +358 9 61580920

France: 4 Rue du Port-aux-Vins, BP317, 92156 SURESNES Cedex,
Tel. +33 1 40 99 6161, Fax. +33 1 40 99 6427

Germany: Hammerbrookstraße 69, D-20097 HAMBURG,
Tel. +49 40 23 53 60, Fax. +49 40 23 536 300

Greece: No. 15, 25th March Street, GR 17778 TAVROS/ATHENS,
Tel. +30 1 4894 339/239, Fax. +30 1 4814 240

Hungary: see Austria

India: Philips INDIA Ltd, Band Box Building, 2nd floor,
254-D, Dr. Annie Besant Road, Worli, MUMBAI 400 025,
Tel. +91 22 493 8541, Fax. +91 22 493 0966

Indonesia: see Singapore

Ireland: Newstead, Clonskeagh, DUBLIN 14,
Tel. +353 1 7640 000, Fax. +353 1 7640 200

Israel: RAPAC Electronics, 7 Kehilat Saloniki St, PO Box 18053,
TEL AVIV 61180, Tel. +972 3 645 0444, Fax. +972 3 649 1007

Italy: PHILIPS SEMICONDUCTORS, Piazza IV Novembre 3,
20124 MILANO, Tel. +39 2 6752 2531, Fax. +39 2 6752 2557

Japan: Philips Bldg 13-37, Kohnan 2-chome, Minato-ku, TOKYO 108,
Tel. +81 3 3740 5130, Fax. +81 3 3740 5077

Korea: Philips House, 260-199 Itaewon-dong, Yongsan-ku, SEOUL,
Tel. +82 2 709 1412, Fax. +82 2 709 1415

Malaysia: No. 76 Jalan Universiti, 46200 PETALING JAYA, SELANGOR,
Tel. +60 3 750 5214, Fax. +60 3 757 4880

Mexico: 5900 Gateway East, Suite 200, EL PASO, TEXAS 79905,
Tel. +9-5 800 234 7381

Middle East: see Italy

Netherlands: Postbus 90050, 5600 PB EINDHOVEN, Bldg. VB,
Tel. +31 40 27 82785, Fax. +31 40 27 88399

New Zealand: 2 Wagener Place, C.P.O. Box 1041, AUCKLAND,
Tel. +64 9 849 4160, Fax. +64 9 849 7811

Norway: Box 1, Manglerud 0612, OSLO,
Tel. +47 22 74 8000, Fax. +47 22 74 8341

Philippines: Philips Semiconductors Philippines Inc.,
106 Valero St. Salcedo Village, P.O. Box 2108 MCC, MAKATI,
Metro MANILA, Tel. +63 2 816 6380, Fax. +63 2 817 3474

Poland: Ul. Lukiska 10, PL 04-123 WARSZAWA,
Tel. +48 22 612 2831, Fax. +48 22 612 2327

Portugal: see Spain

Romania: see Italy

Russia: Philips Russia, Ul. Usatcheva 35A, 119048 MOSCOW,
Tel. +7 095 755 6918, Fax. +7 095 755 6919

Singapore: Lorong 1, Toa Payoh, SINGAPORE 1231,
Tel. +65 350 2538, Fax. +65 251 6500

Slovakia: see Austria

Slovenia: see Italy

South Africa: S.A. PHILIPS Pty Ltd., 195-215 Main Road Martindale,
2092 JOHANNESBURG, P.O. Box 7430 Johannesburg 2000,
Tel. +27 11 470 5911, Fax. +27 11 470 5494

South America: Rua do Rocio 220, 5th floor, Suite 51,
04552-903 São Paulo, SÃO PAULO - SP, Brazil,
Tel. +55 11 821 2333, Fax. +55 11 829 1849

Spain: Balmes 22, 08007 BARCELONA,
Tel. +34 3 301 6312, Fax. +34 3 301 4107

Sweden: Kottbygatan 7, Akalla, S-16485 STOCKHOLM,
Tel. +46 8 632 2000, Fax. +46 8 632 2745

Switzerland: Allmendstrasse 140, CH-8027 ZÜRICH,
Tel. +41 1 488 2686, Fax. +41 1 481 7730

Taiwan: Philips Semiconductors, 6F, No. 96, Chien Kuo N. Rd., Sec. 1,
TAIPEI, Taiwan Tel. +886 2 2134 2865, Fax. +886 2 2134 2874

Thailand: PHILIPS ELECTRONICS (THAILAND) Ltd.,
209/2 Sanpavuth-Bangna Road Prakanong, BANGKOK 10260,
Tel. +66 2 745 4090, Fax. +66 2 398 0793

Turkey: Talatpasa Cad. No. 5, 80640 GÜLTEPE/ISTANBUL,
Tel. +90 212 279 2770, Fax. +90 212 282 6707

Ukraine: PHILIPS UKRAINE, 4 Patrice Lumumba str., Building B, Floor 7,
252042 KIEV, Tel. +380 44 264 2776, Fax. +380 44 268 0461

United Kingdom: Philips Semiconductors Ltd., 276 Bath Road, Hayes,
MIDDLESEX UB3 5BX, Tel. +44 181 730 5000, Fax. +44 181 754 8421

United States: 811 East Arques Avenue, SUNNYVALE, CA 94088-3409,
Tel. +1 800 234 7381

Uruguay: see South America

Vietnam: see Singapore

Yugoslavia: PHILIPS, Trg N. Pasica 5/v, 11000 BEOGRAD,
Tel. +381 11 625 344, Fax. +381 11 635 777

For all other countries apply to: Philips Semiconductors, Marketing & Sales Communications,
Building BE-p, P.O. Box 218, 5600 MD EINDHOVEN, The Netherlands, Fax. +31 40 27 24825

Internet: <http://www.semiconductors.philips.com>

© Philips Electronics N.V. 1997

SCA55

All rights are reserved. Reproduction in whole or in part is prohibited without the prior written consent of the copyright owner.

The information presented in this document does not form part of any quotation or contract, is believed to be accurate and reliable and may be changed without notice. No liability will be accepted by the publisher for any consequence of its use. Publication thereof does not convey nor imply any license under patent- or other industrial or intellectual property rights.

Printed in The Netherlands

547027/1200/01/pp108

Date of release: 1997 Aug 01

Document order number: 9397 750 01998

Let's make things better.

Philips
Semiconductors



PHILIPS